

INSTALLATION GUIDE

Outback® Flat Attached

VERANDAHS | PATIOS | CARPORTS



BEFORE YOU START

It is important to check your Local Government Authority requirements before the installation of your new Stratco Outback® Flat Verandah. It is the builder's responsibility to ensure any existing structure that an Outback Flat is being attached to is adequately reinforced to accommodate the additional loads imposed by the verandah, patio or carport. Read these instructions thoroughly before starting your project and refer to them constantly during each stage of construction. Contact Stratco for advice if you do not have the necessary tools or information.

Before starting, lay out the main components in order of assembly on the ground and check them against the delivery note. The 'Components' section identifies each part of your Outback Flat Verandah or Carport and shows the relative location of the components.

Mark out the overall area of your verandah, patio or carport and ensure that it is free from obstructions. Beam to wall connections can cause difficulty if they coincide with door and window openings, so avoid these in your design. Ensure there is reasonable access for materials and working space and consider the disposal of run-off water. Check the column and beam positions on the ground; roughly check they are square by measuring the diagonals, then mark out the column locations. If columns are to be 'in ground', dig the holes to Stratco specifications.

ADDITIONAL MATERIALS

The Outback kit does not include fixings to attach the unit to an existing structure or concrete/masonry anchors for the column installation. If required, they must be purchased as additional items.

TOOLS REQUIRED

- Drill & Hex/Phillips Head Adaptors
- Rivet Gun
- Tape Measure
- Tin Snips
- Spirit Level
- Hack-Saw
- Post Hole Digger
- Silicone Gun
- Spanner or Ratchet
- Adjustable Construction Props
- Turn Up/Down Tool
- Concrete
- Ladder



COMPONENTS

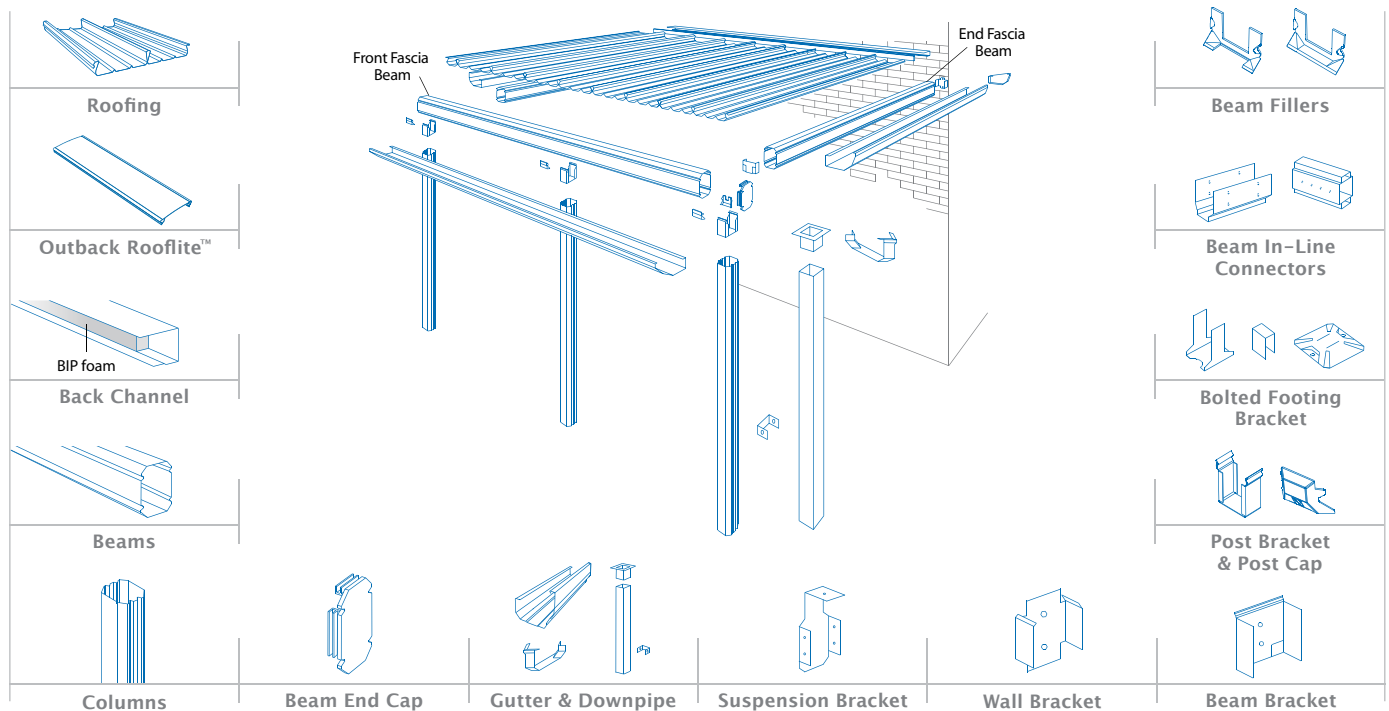

BACK CHANNEL INSTALLATION

Back Channel

The stepped edge of the back channel is the underside. The back channel should extend 50mm past the end of the beam to allow for overflow into the gutter. If multiple lengths are required, butt the channels together and waterproof with silicone.

Determine what type of fascia you are attaching your unit to and what type of fixings and brackets you require. Pre-drill the back channel on the ground. Locate the first hole 100mm from the edge of the back face of each length of channel. Drill the other holes at 500mm centres for timber and brickwork or 250mm centres for steel fascia. Run two beads of silicone along the back of the back channel, with one near the top edge to ensure a water tight seal.

Fascia Attachment

When fixing the back channel to fascia, the roofing above each rafter must be removed to give adequate space to install the fascia strengthening brackets. M10 Bolts connect the brackets to the rafter and fascia (the number of brackets required is determined by the builder, but the spacing should not exceed 1200mm). Silicone as shown in the diagrams. When fixing to timber fascia (Figure 1.0) attach the back channel using 12x25mm hex head timber fixing screws through the pre-drilled holes. When fixing to steel fascia (Figure 1.2) attach the back channel using 10x16mm hex head self drilling screws through the pre-drilled holes. The back channel is bolted through the fascia to the fascia brackets with one M10 bolt per bracket. Insert BIP foam into the back channel, which acts as a weather seal when the roof sheets are pressed into it.

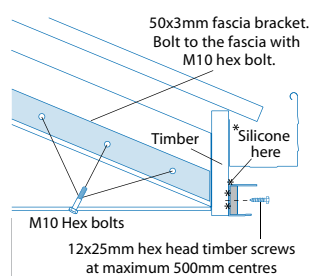

Figure 1.0

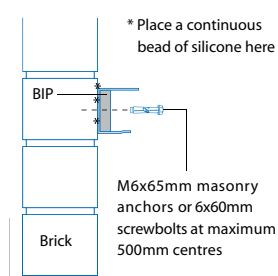

Figure 1.1

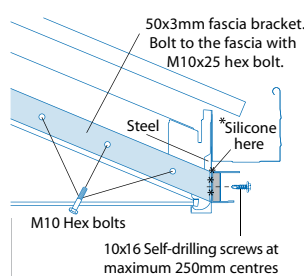

Figure 1.2

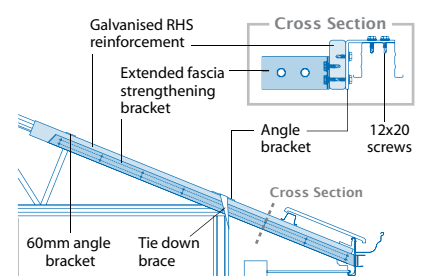

Figure 1.3

Attaching to a Brick Wall

When fixing the back channel to a brick wall, pre-drill the anchor holes using a masonry drill bit. Attach the back channel using M6x65mm masonry anchors through the pre-drilled holes (Figure 1.1). Insert the BIP foam into the back channel, which acts as a weather seal when the roof sheets are pressed into it.

Steel House Frame Attachment

When fixing the back channel to the steel fascia on a steel framed house, the roofing above each rafter must be removed to allow enough room to install the rafter strengthening brackets.

Attach angle brackets to 75x25x1.6mm RHS reinforcement using 12x20 self drilling screws. Place the brackets above the first web or truss connection at least 900mm from the wall, and directly over the wall. Fasten with four 12x20 self drilling screws to the chord or rafter (Figure 1.3).

Attach the extended fascia strengthening bracket to the reinforcing RHS using 12x20 self drilling screws at 200mm centres. It is the builder's responsibility to determine the adequacy of the fascia and rafters and the frequency of the brackets for each individual situation (Figure 1.3).

For additional bracing, fix a tie down brace to the adjacent studs. Use two 12x20 self drilling screws to fix the tie down to the top chord, and on each stud use two 12x20 self drilling screws on either side of the truss or rafter. Fix the back channel to the fascia as previously mentioned.

BRACKETS

Wall Bracket

For units attached to a wall, position the wall brackets where the beams meet the wall. The folded section on the tabs of the bracket is located at the top. The highest point of the wall bracket will be 15mm below the top of the beam. Mark the holes and drill using an 8mm masonry bit. Fasten the bracket to the wall with two M8 masonry anchors to a minimum 65mm embedment. The beam is slid into position and fastened with four 10x16 self drilling screws (Figure 2.0).

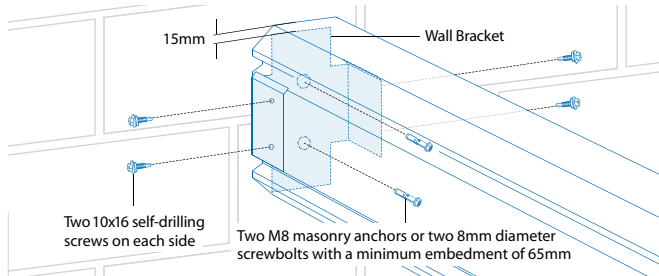

Figure 2.0

Suspension Bracket

A suspension bracket is used when a beam is suspended from the fascia. The top tab of the bracket must be located between the fascia and the back channel. Use silicone to seal behind the suspension bracket and fascia. For steel fascia a minimum of three 10x16 hex head screws are fixed through the back channel, suspension bracket and fascia. For timber, three 12x25 type 17 screws are used to fix through the back channel, suspension bracket and timber. The beam is slid into position and fastened using four 10x16 self drilling screws (Figure 2.1).

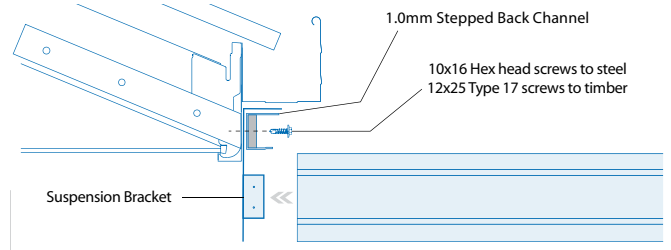

Figure 2.1

BEAMS

End Fascia Beam

When installing all beams, ensure the double thickness of the beam is on top. Install the end fascia beam furthest from the downpipe first. Lift the back channel end of the beam up into the wall or suspension bracket while supporting the other end on an adjustable construction prop. Adjust the construction prop to allow for the required deck fall minimum of one degree (or one and a half degrees for deck spans over 4000mm). Fasten the end fascia beam to the bracket using two 10x16 hex head screws either side in the holes provided.

Bracket and Filler Connections

Measure the front fascia beam. Mark where the end fascia beams, intermediate beams (if required) and columns meet. Clip the post brackets onto the bottom of the front fascia beam where the columns will sit.

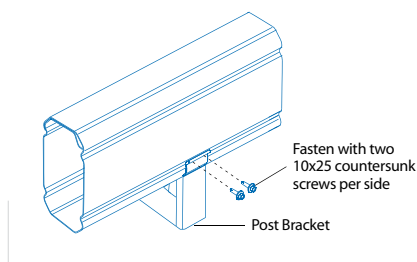

Figure 3.0

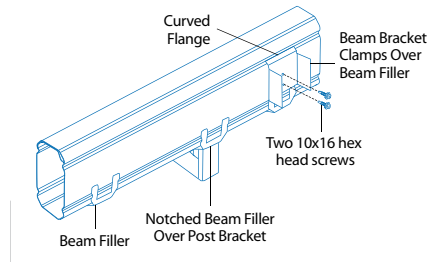

Figure 3.1

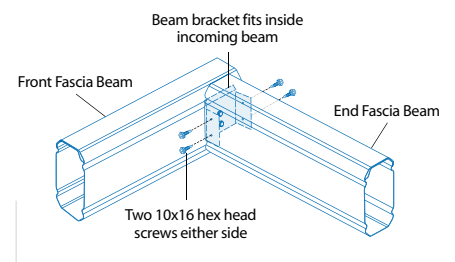

Figure 3.2

In-Line Beam Connection

To butt join beams together, an in-line beam connector is used. The connector is placed so the join is in-line with the edge of a column. On the ground, slide the connector into the end of the beam. Fix using four 10x16 hex head screws either side. Push the exposed half of the in-line connector into the other beam until both beams meet flush and fasten as previously described (Figure 3.3). The post bracket at the in-line connection can now be fixed in place. Fasten using two 10x20 countersunk screws into the flute of the beam on each side.

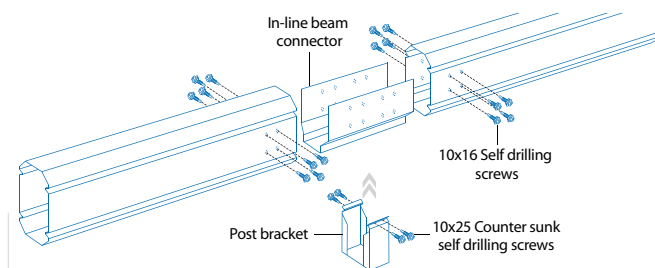

Figure 3.3

Full Moment Beam Connection Detail

If the beams must be joined at a location other than over a post, a full moment beam connector is required (Figure 3.4). Slide the connector halfway inside the beam while it is still on the ground. Fix the connector in place using six 12x20 hex head screws; two either side of the beam and two on the top of the beam. Push the exposed half of the in-line connector into the other front fascia beam until both beams meet flush and fasten using six 12x20 hex head screws; two either side of the beam and two on the top of the beam.

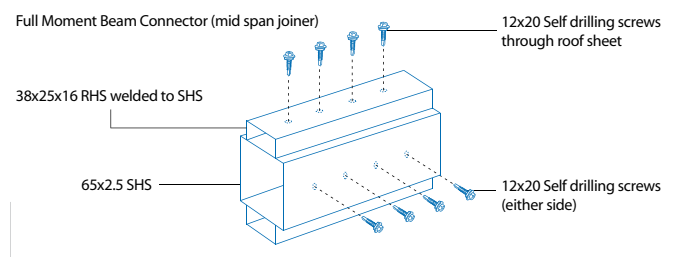

Figure 3.4



Intermediate Beams and Purlins

If intermediate beams and/or purlins are required, they may be fitted at this stage or following installation of the columns. Work progressively from the first end of the unit. Locate the beam brackets and wall or suspension brackets in the correct positions and fasten as previously described. Lift the first intermediate beam into place and support on adjustable construction props, if purlins are required (i.e., type 4A Outback unit) do not secure the intermediate beam until the first purlin is lifted into position (Figure 3.5). Secure all connections using

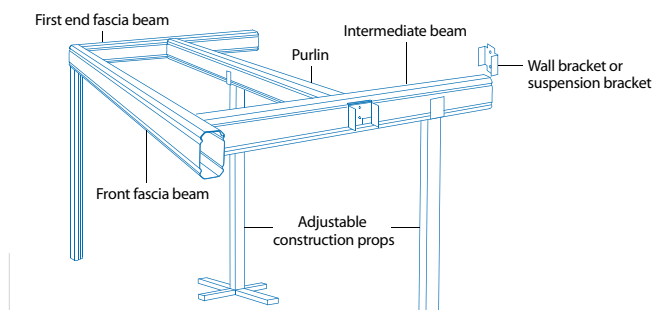

Figure 3.5

two 10x16 hex head screws either side of each bracket. Continue this process along the Outback unit until the final end fascia beam is fixed in place.

Framework Check

Check that the basic framework is square by ensuring the diagonal measurements are the same. Recheck the falls are correct for the roof and gutter (Figure 3.6).

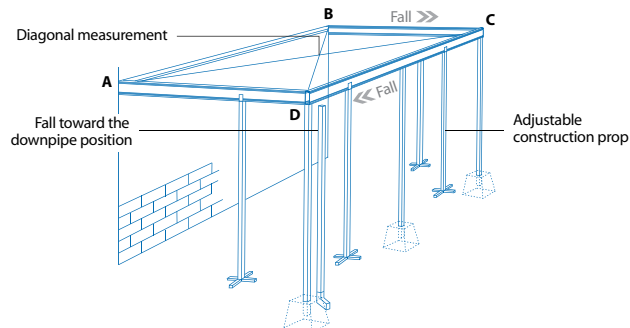

Figure 3.6

COLUMNS AND FOOTINGS

Columns and Footings

If fixing the columns into the ground, dig the holes to the specified size and place a half brick in the bottom of the hole (Figure 4.0). At each post location, measure from the underside of the beam to the top of the brick and cut the columns to length. Check to ensure all columns are plumb.

Attached Verandah Footing Plate

A bolted footing bracket is available if fixing posts to an existing concrete slab. Establish the column lengths by measuring the distance from the underside of the fascia beam to the concrete slab and deduct 20mm to allow for the depth of the footing bracket and cut the columns to length. Assemble the footing bracket by sliding the legs of the footing upstand through the slots in the plate (Figure 4.1). The upstand bracing must be located between the legs of the

upstand. Slide the assembled footing bracket and bracing into the bottom of the column, and fasten with two 12x20 hex head screws either side ensuring the top screws are located at least 15mm from the top of the upstand with screws being a minimum 30mm apart.

Attach Column to Post Bracket

Slide the top of the column over the post bracket and align the column and footing bracket if applicable. It may be necessary to lift the fascia beam to slide the column over the post bracket. The un-fluted faces of the column should be aligned with each face of the post to beam bracket. Fasten with two 12x20 hex head screws either side (Figure 4.2). Post caps are used to cover the screw heads, press firmly into position, silicone can be used to provide a better fixing.

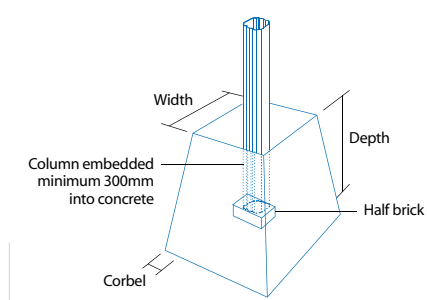

Figure 4.0

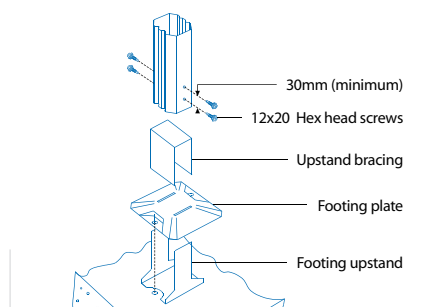

Figure 4.1

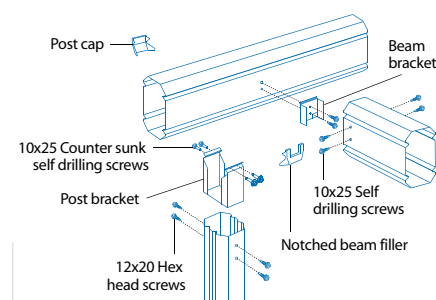

Figure 4.2

BEAM CAPS AND FILLERS

Beam Caps

Any beams with exposed ends require end caps be fitted. Align the end cap and push into the exposed beam end (Figure 5.0).

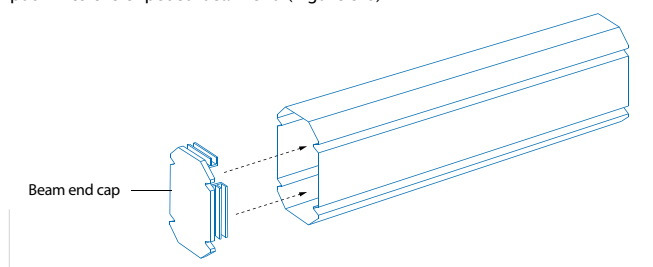

Figure 5.0

Beam Fillers

If a downpipe is to run flush with a column, place a notched beam filler over the exposed post bracket and use silicone to hold it in place (Figure 5.1).

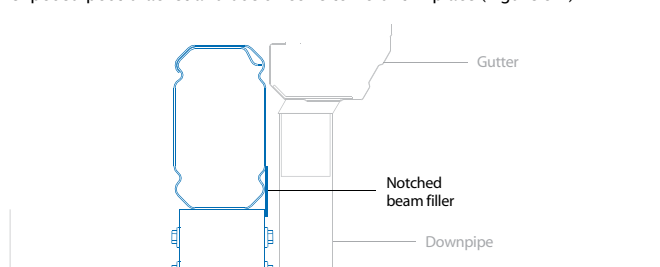

Figure 5.1

DECKING

Turning the Decking Ends

While still at ground level, the ends of the decking need to be turned up or down approximately 30 degrees using a turn up/down tool to aid in weather proofing. Turn the ends of the decking up at the back channel end and down at the gutter end (Figure 6.0).

Laying and Installing the Decking

Decking should have a 50mm overhang into the gutter and is laid with the overlapping rib facing away from the prevailing wind (Figure 6.1). Ensure all of the sheets have locking ribs on the same side. Mark the back channel and front fascia beam every 1000mm to check the decking is laid square.

Lift the first sheet into place and push it firmly into the BIP foam in the back channel to weather proof it. Check the sheet is square against the back channel and side fascia beam. At the back channel end, rivet the decking from underneath through the raised edge on the bottom of the back channel with two 3.2mm rivets per pan (Figure 6.2). Seal the rivets with silicone. At each supporting beam, fix the sheet with two 12x20 hex head self-drilling screws per pan (Figure 6.2) (In cyclonic conditions use three 12x20 hex head

self-drilling screws per pan on supporting beams and three rivets per pan at the back channel). Remove any swarf.

Lay the next sheet of decking over the previous sheet's side lap (Figure 6.1). At the back channel end press down on the lap until the sheets clip together, continue working along the length of the sheet using a timber block (to avoid damaging the sheet) and rubber mallet. Finish by sliding the roof sheet firmly into the BIP foam on the back channel. For larger spans you may need to temporarily support the underside of the roof sheeting while clipping the laps together. Continue this process until all the roof decking is installed.

Decking Parallel to Back Channel

If the decking runs parallel to the back channel, slide the first roof sheet sideways into the BIP foam in the back channel for a weather proof seal. The sheeting is secured to the back channel with rivets at 200mm centres (150mm centres for cyclonic conditions), and it is secured to the beams running parallel with the decking using hex head screws at 500mm centres. The roof sheets are fixed as standard to the supporting beams (Figure 6.2).

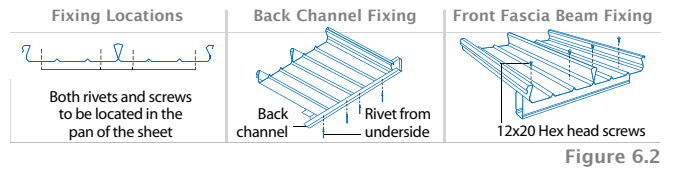
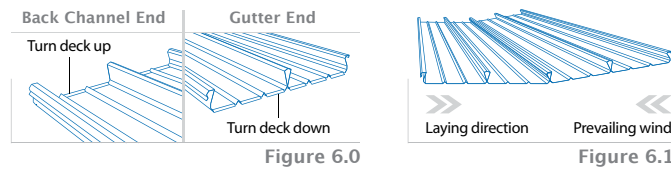

OUTBACK ROOFLITE™ INSTALLATION

An Outback Rooflite can be used to add natural light. The polycarbonate Rooflite overlaps the deck by snapping or sliding over the already installed sheets that have been spaced 250mm apart (note the profile of the Rooflite is different on each side, and therefore must align with the correct connection on the deck). Ensure the lower tab of the Rooflite touches the Outback deck at the points shown (Figure 7.0) and all sheeting is pushed firmly into the back channel. 9mm holes must be pre-drilled through the Rooflite at all of the fastener locations prior to fixing to allow for thermal expansion. The

Rooflite is fastened using 12x20mm hex head self-drilling screws with domed washers at maximum 2000mm centres. Fix through the groove located along the top of the Rooflite connectors (Figure 7.1). To finish the exposed end of the Rooflite an infill is required. Fasten the infill over the Rooflite with 12x20mm screws and domed washers on both sides through the pre-drilled holes. Connect the infill to the underside of the decking with 3mm rivets, seal the rivets with silicone. Finally, a foam insert is placed into the backchannel end of the Rooflite.

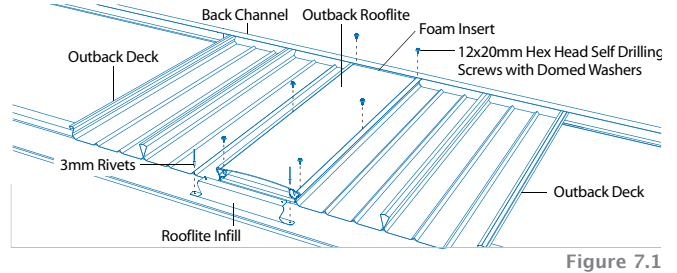
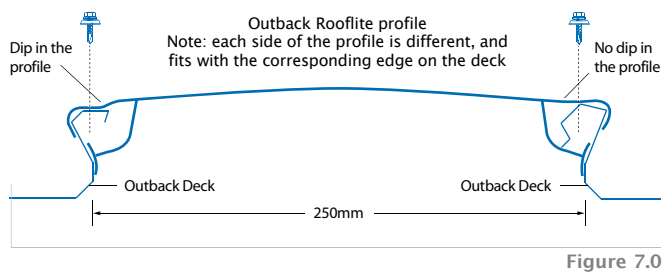

GUTTER ASSEMBLY

Gutter Preparation

To establish the inside gutter length 'A' (Figure 8.0), measure from the back of the back channel to the outside of the front fascia and subtract 5mm for the mitre bracket. To establish the inside gutter length for units with a deck overhang, subtract 55mm from the total roof sheet length. To establish inside gutter length 'B' for the front gutter, measure the length of the front fascia beam and subtract 5mm for each mitre bracket.

Attach the stop ends to the side gutters with four rivets per stop end. Remove any swarf and waterproof with silicone. On the gutter ends that will form a corner, cut a 45 degree mitre. Fit the mitre brackets using 3mm sealed rivets to fasten the mitre to the gutter then waterproof with silicone.

First Side Gutter Assembly

After fixing a gutter mitre bracket to the corner of the first side gutter, lift the gutter into place so the stop end slides up behind the back channel. Use rivets to fasten the gutter's back lip to the roofing at the maximum spacing of one metre. Install the gutter straps at least every metre (Figure 8.2). Waterproof the rivets with silicone. Ensure the front face of the gutter remains vertical and even.

Front Gutter Assembly

On the front gutter, attach a gutter mitre to the end opposite the side gutter. Slide the flat end of the gutter straps inside the rib of the roof sheets every metre. Hang the front gutter on the gutter straps and using a rolling action,

CONTACT

1300 165 165

lift the back of the gutter into the corner mitre of the side gutter. Check the roof sheets overhang into the gutter by 50mm and the gutters are square in relation to the framework. Fix the front gutter with rivets at one metre spacings through the end of the roof sheets into the gutter's back lip. For units with a deck overhang, fix the gutter to the roof sheets with two rivets per pan. Rivet and seal the front gutter to the mitre and the gutter straps to the roof sheets. Lift the final side gutter so that its front end slides into the mitre and the stop end slides up behind the back channel. Fix the gutter in position as previously described and waterproof with silicone. The downpipe is not attached at this stage, as the columns are not yet fixed in their vertical position.

Gutter Outlet Assembly

To mark the position of the outlet, place the downpipe in line with the column. Mark and cut a hole in the base of the gutter near the back chamfer. Insert the downpipe outlet from the inside of the gutter and rivet in place using 3.2mm rivets (Figure 8.1). Remove any swarf and waterproof with silicone.

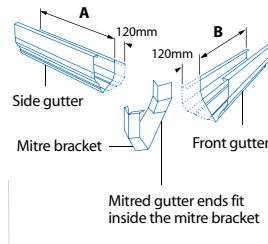

Figure 8.0

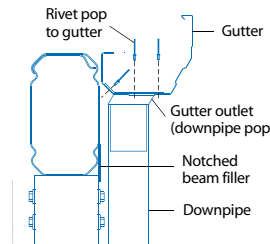

Figure 8.1

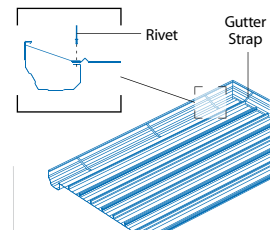

Figure 8.2

FINAL FIXING

Final Fixing into the Concrete Footing

Thoroughly check the posts with a spirit level. When plumb, fill the post hole with approximately 150mm of concrete and use a shovel or pole to agitate the concrete to remove any air pockets. Repeat this process until the hole is full, continually checking the posts as you go. The concrete must have a slight slope that runs away from the column to ensure any water does not pool around the base (Figure 9.0). Once the concrete is set remove any temporary bracing or props.

Final Fixing onto Existing Concrete

If the columns are to be fixed to an existing concrete slab with a footing plate, each plate must be fixed to the concrete with two M12x75 masonry anchors or two M12x75 screwbolts (Figure 9.1). The minimum distances from an anchor hole to the concrete edge is 75mm for M12 anchors.

Important Note

Do not allow soil to remain in permanent contact with the columns, as corrosion will result in the base of the column. Refer to the "Selection, Use and Maintenance of Stratco Steel Products" brochure for complete details of the maintenance requirements.

Downpipes

Before attaching the downpipes, rivet the downpipe bracket to the column and bend the flanges along the 'break-line' to accept the downpipe. Slide the downpipe over the downpipe outlet and rivet into position. Rivet the downpipe to the brackets. Weatherproof all the fasteners with silicone.

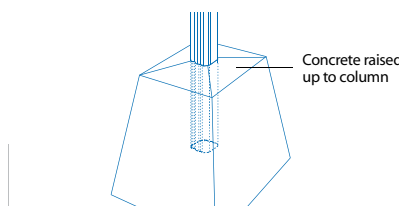

Figure 9.0

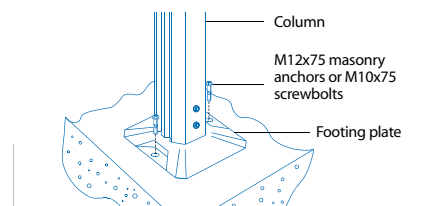

Figure 9.1

MAINTENANCE

Regular maintenance is essential to maintain the good looks of all Stratco steel products and to ensure you receive the maximum life-span possible. Washing with clean water must be frequent enough to prevent the accumulation of dust, salts, and pollutants that may reduce the life of the product. Stratco steel products that are regularly washed by rain require no additional maintenance. No Stratco steel structure or materials are recommended for use over, or in close proximity, to swimming pools or spas. No material that retains water (such as dirt or paving sand) should be placed against the columns. Care must be taken when determining the location of Stratco steel products so that they are not placed in close contact with sources of pollution or environmental factors that could affect the life of