

## Outback Gable

CLEARSPAN ATTACHED



### BEFORE YOU START



Carefully read these instructions, along with the 'Outback Flat Attached Installation Guide'. Lay out the main components in order of assembly on the ground and check them against the delivery note. The 'Components' section identifies each part of your Stratco Clearspan Gable and shows the location of the components.

Mark out the overall area of your verandah, patio or carport and ensure it is free from obstructions. Beam to wall connections can cause difficulty if they coincide with door and window openings, so avoid these in your design. Ensure there is reasonable access for materials and working space and consider the disposal of run off water. Check the post and beam positions on the ground, roughly check they are square and mark the hole locations.

If you do not have all the necessary tools or information, contact Stratco for advice. Before starting lay out all components and check them against the delivery docket. The parts description identifies additional gable parts, and the component layout diagram indicates their fastening position.

### TOOLS REQUIRED

- Drill & Hex-Head Adaptor
- Rivet Gun
- Tape Measure
- Tin Snips
- Spirit Level
- Hack-Saw
- Post Hole Digger
- Silicone Gun
- Spanner or Ratchet
- Adjustable Construction Props
- Turn Up/Down Tool
- Concrete



# COMPONENTS

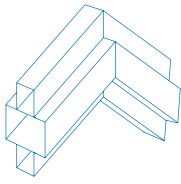

### RIDGE KNUCKLE

Slots inside the gable rafters to form connection at the ridge.

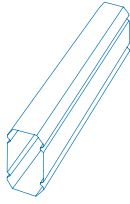

### RAFTERS

Gable Rafters consist of pre-cut 120 Outback beam.

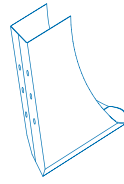

### RAFTER TO VALLEY BRACKET

This bracket fastens the rafter to the valley beam.

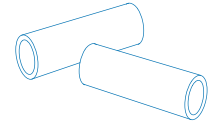

### SPACERS

Used to prevent the 150 attachment beam from crushing

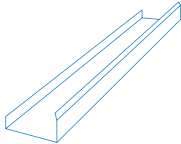

### SOAKER FLASHING

Water proofs the rear of the gable and conceals the existing house gutter.

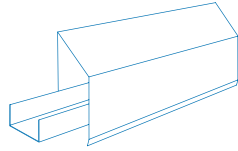

### BEAM CAPPING

Fixed to top of the valley beam to provide support for outback deck.

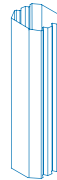

### END STRUT

Consists of a section of post. Supports the gable in-fill.



### 22 OR 30 END STRUT PLATE

Secures the end strut at the ridge.

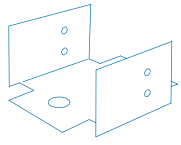

### HEADER BEAM BRACKET

Connects end strut to header beam on an in-fill gable.

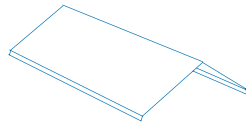

### RIDGE CAP

This flashing covers the roof sheets at the gable ridge.

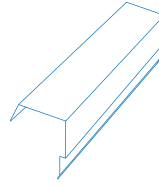

### BARGE CAP

The barge cap covers the area where the deck finishes at portal frame.

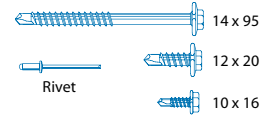

### SCREWS AND RIVETS

Vary depending upon the connection, ensure correct fixings are used.

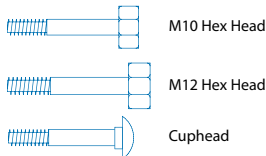

### BOLTS

Vary depending upon the connection, ensure correct fixings are used.

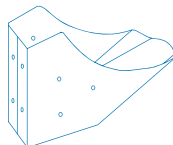

### GABLE BEAM BRACKET

Connects rafters to header beam on an in-fill gable

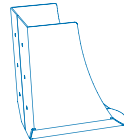

### RIDGE RAFTER BRACKET

Connects ridge beam to rafters on a gable.

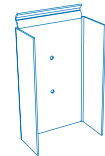

### BEAM TO BEAM BRACKET

Connects horizontal beams.



### BEAM FILLER

Fills gap between intersecting Beams.

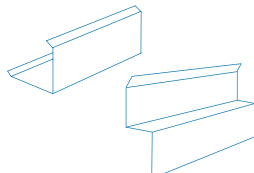

### HEADER FLASHINGS

Run along header beam to neatly finish the base of in-fill panels.

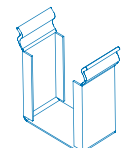

### POST BRACKET

Connects post to beam.

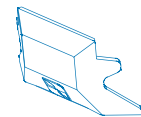

### POST CAP

Fills gap between post and beam.

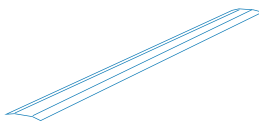

### PANEL STRIPS

Decorative strips fixed to in-fill panels.

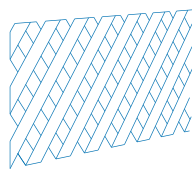

### IN-FILL PANEL

Cut to suit gable end frames.



### FINIAL

Provides decoration at the apex of the gable end frame.

## ADDITIONAL MATERIALS

Please note that the Stratco Outback kit does not include any brackets or fixings to attach the unit to the existing structure, or concrete/masonry anchors for column installation. Other items not included in the standard kit are infill panels and accessories, finials, box gutters, cover flashings and concrete.

## COMPONENT LAYOUT

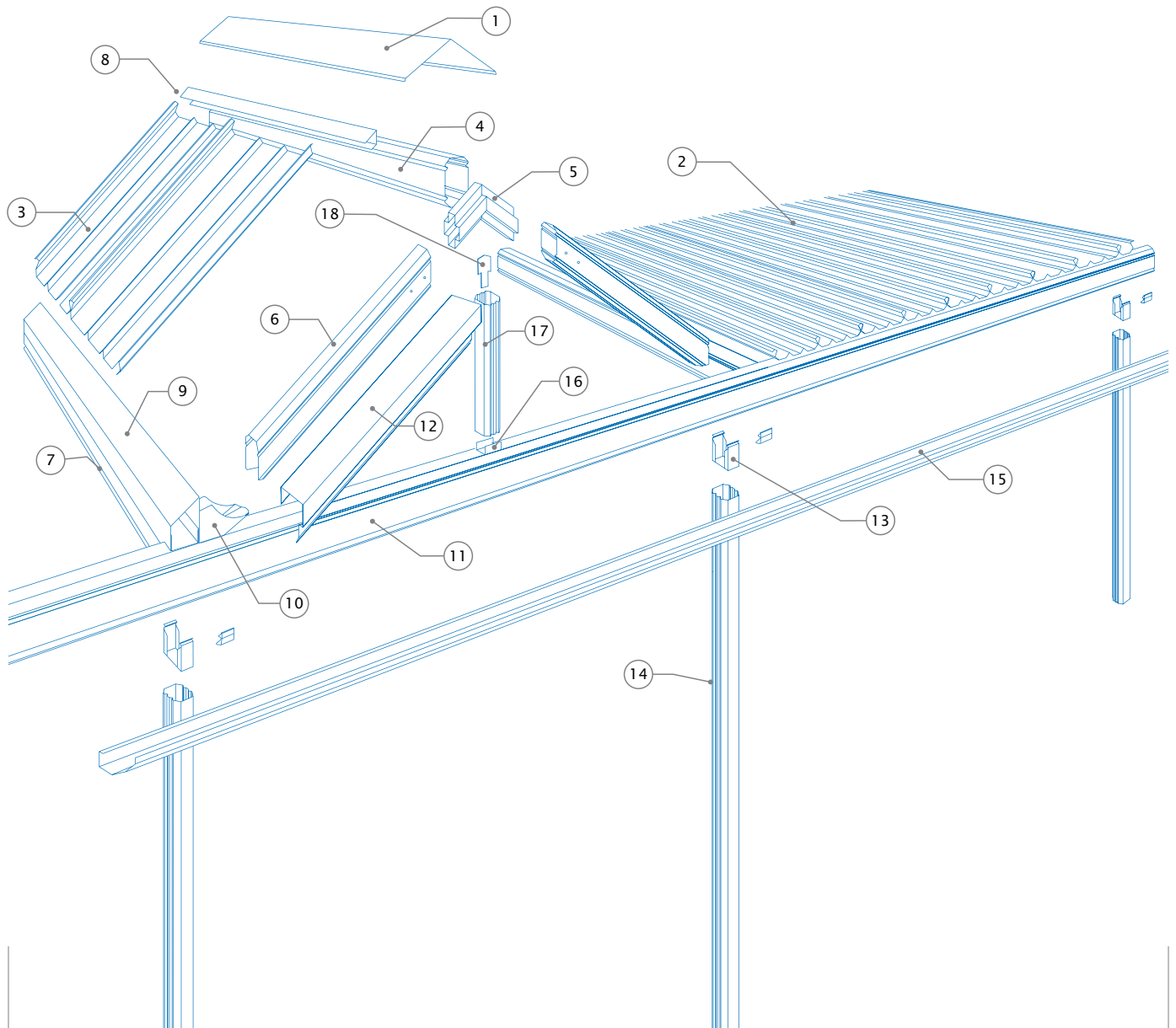

① Ridge Capping

② Flat Section

③ Outback Deck

④ Ridge Beam

⑤ Ridge Knuckle

⑥ Gable Rafter

⑦ Valley Beam

⑧ Angle Back Channel

⑨ Beam Capping

⑩ Gable Beam Bracket

⑪ Header Beam

⑫ Barge Cap

⑬ Post Bracket

⑭ Post

⑮ Gutter

⑯ Header Beam Bracket

⑰ End Strut

⑱ End Strut Plate



# INTRODUCTION

Please read these assembly instructions thoroughly before commencing the construction. Double check all dimensions, levels and bolting locations before cutting, screwing or bolting structural members. It is recommended that the persons erecting the structure have had some previous building experience because some modifications to the existing house structure are required.

# ATTACHING TO AN EXISTING STRUCTURE

The builder is to ensure the existing house/structure is of a suitable structural integrity and complies with all the relevant Australian Building codes and standards. For more information regarding the suitability of the house structure to accommodate the Stratco Attached Clearspan Gable, consult a structural engineer or a building authority. It is the builder's responsibility to ensure that the existing house roof structure is strengthened correctly.

Refer to section 2.1 if attaching Clearspan Gable on its side to a house, section 2.2 if attaching on its end to a house or refer to both sections if attaching the gable on its side and end.

## Attaching On Side To House

A Stratco Clearspan attached on its side to a house is attached to the existing eaves overhang at the fascia, or to an existing wall if height permits.

The first objective in the construction is to fix a structural side beam along the fascia or wall, to which the Gable Unit is attached.

Most existing houses have not been designed for the attachment of portal framed gables to their side, therefore additional strengthening of the house rafters must be performed.

In order to strengthen the existing house rafters, the roof tiles or roof sheets need to be lifted to expose the roof frame. Steel rafter brackets and channels are then bolted along the house rafters. Refer to section 2.1.1.

A 150mm Outback beam is bolted to the strengthening brackets at the fascia. Once the 150 attachment beam is secured to the house, the Gable Unit can be erected and fastened to the beam.

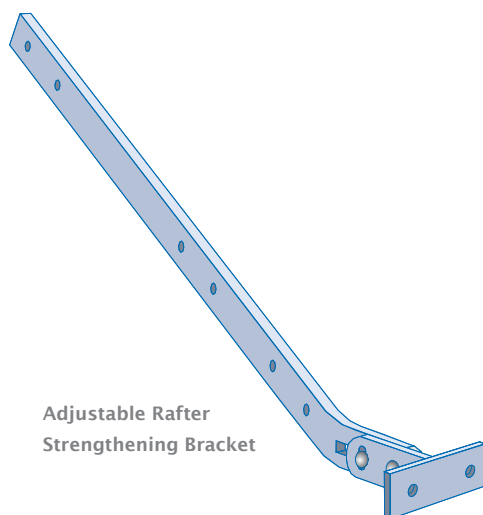

Figure 2

## Rafter Strengthening

The first step is to determine the number of rafters which need to be strengthened and their location relative to the unit. You will have to lift some roof tiles or roof sheets to discover the rafter positions and spacings. The number of rafters which need to be strengthened is determined by the builder, however spacing is recommended not to exceed 1200mm.

Note: It is the builder's responsibility to ensure the existing rafters and fascia are adequately reinforced and strengthened to accommodate any additional attached structure. The reinforcing method must be approved by the appropriate council or engineer.

It is recommended an adjustable rafter strengthening bracket is used in conjunction with an extension channel, as shown in (Figure 3).

The adjustable rafter strengthening bracket is shown in (Figure 2). Please note that this bracket may not be suitable for applications where the front face of the house gutter is higher than 120 mm. In these cases please contact Stratco for alternative solutions.

The adjustable rafter strengthening bracket allows for an adjustment of pitch in the range of 15 to 30 degrees. The distance the bracket extends past the fascia is also adjustable to allow for standard gutters (minimum extension) or box gutters with a width of up to 200mm.

In conjunction with rafter strengthening brackets a channel is fixed to the side of the house rafter (Figure 3). The bottom end of the channel will be located at the base of the house rafter. Holes should be marked and pre-drilled in the channel to suit the location of existing holes in the bracket. The channel will extend beyond the bracket so additional holes are to be drilled in the channel at approximately 500mm centres.

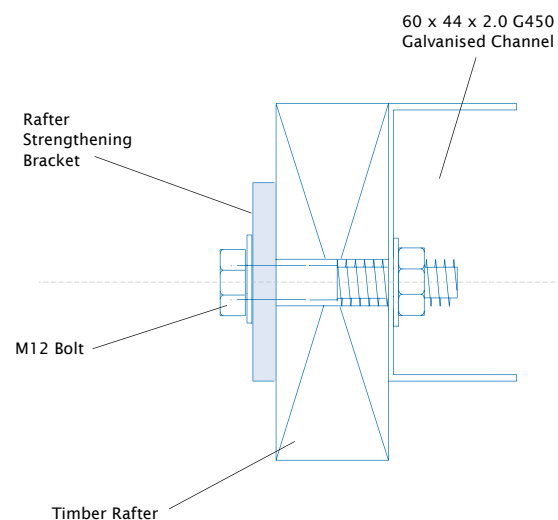

Figure 3

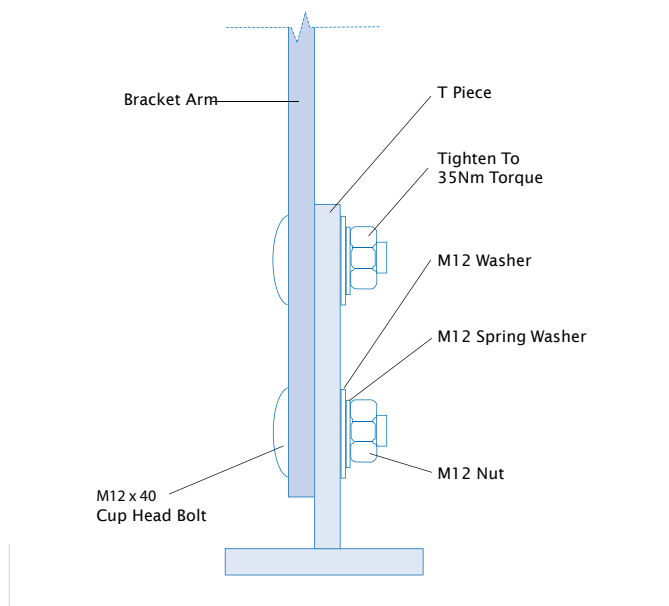

Figure 4

Initially the bracket T piece shall be fixed to the bracket arm with two M12 cup head bolts (hand tighten only), a spring washer is to be located between the standard M12 washer and nut (Figure 4). Mark the position of the bracket on the fascia and notch a rectangular hole in the fascia allowing the bracket to be fed through the front of the fascia.

The hole may need to be enlarged slightly if the M12 cup head bolts interfere with the fascia. Insert the bracket through the fascia and fix with the channel to the house rafter using M12 hex head bolts through the existing holes in the bracket and further up the channel (Figure 6). Adjust the T piece so it is horizontal and has the appropriate extension past the fascia to allow for fixing of the attachment beam. T piece connection bolts are to be tightened to a minimum 50Nm torque.

Fix the bracket as close to the base of the gutter as possible (recommended minimum distance 10mm from lowest end of gutter), as shown in (Figure 50).

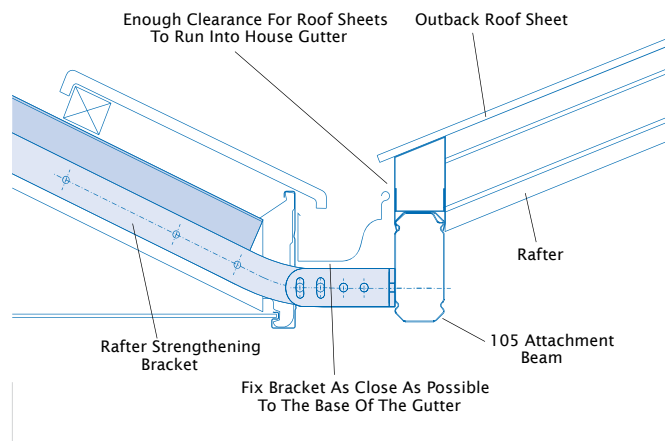

Figure 5

The 150 attachment beam is fixed to the end plate to ensure the carport roof sheets drain into the existing house gutter (Figure 5).

After fixing all the brackets and channels, the 150 attachment beam is fixed in place.

Prop up the 150 attachment beam in position with the double flange on top, the beam will need to be located at a height on the bracket which allows clearance between the gable roof sheets and the gutter. Fix to the end plates of the rafter bracket using two M12 bolts, with the bolt head on the 150 attachment beam side. Insert spacers to prevent the beam from crushing, and bolt in position, using nuts and washers.

The 150 attachment beam becomes the base for the attachment of the Clearspan Gable unit. (Figure 6) shows a unit attached at the side.

Note: Do not over tighten bolts as this can lead to a visible indentation due to the high gloss nature of the material. Refer to (Figure 7) for fixing spacers.

To insert spacers drill 13mm holes through the 150 attachment beam. Then drill 16mm holes on the outside face only, ie, this time do not drill all the way through. This will allow the spacer to slide in from the outside and stop at the other side as shown in (Figure 7).

A cover flashing may be ordered as an additional option and custom made to cover the exposed brackets and holes through fascia. Rivet flashings in place, (Figure 8) suggests a simplified flashing.

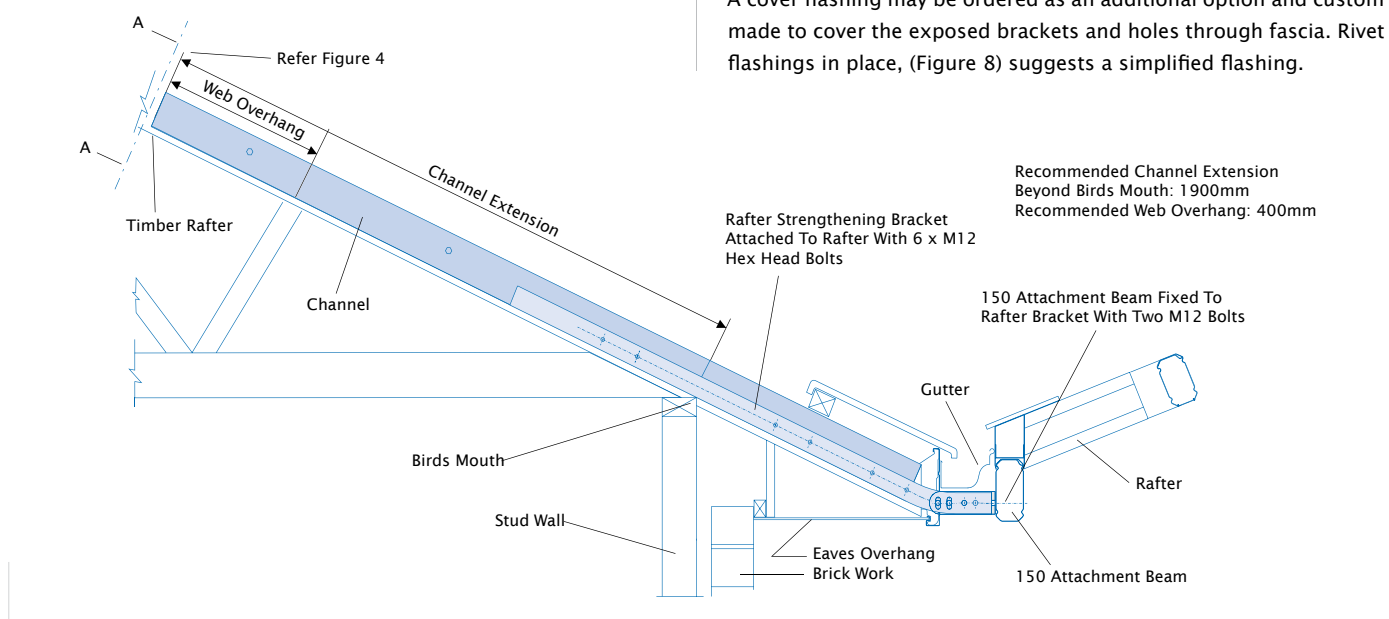

Figure 6

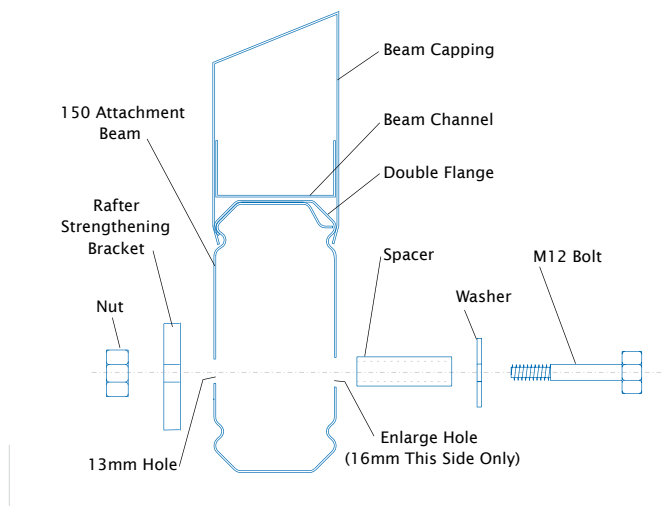

Figure 7

## 2.2 Attaching On End To House

If fixing a Clearspan Gable on its end to a wall, two alternatives are available. Ridge and valley beams are fixed directly to the wall using beam to wall brackets. This option will not require a rear gable frame and back channel is fixed to the wall to accommodate sheets running along the wall. The other alternative requires valley beams be fixed to the wall and a rear gable frame installed. The rear gable frame will need to be slightly offset from the wall to allow the appropriate bracket fixing.

If fixing a Clearspan Gable on its end with suspension brackets to a fascia (Figure 9) typically a soaker flashing is used. In this case the gable rafter at the rear of the unit is to be set back sufficiently from the house fascia to accommodate the house gutter and infill panel (refer to Figures 22 and 23).

If fixing a Clearspan Gable on its end to an attachment beam, elevated to the existing house gutter height, the attachment beam is to be as close as possible (within 5mm) to the outside face of the gutter (Figure 24). The 150 attachment beam is fixed to rafter strengthening brackets as detailed in section 2.1.1.

### 2.2.1 Fascia Strengthening

It is recommended extended fascia strengthening brackets are fastened at a spacing not exceeding 1200mm centres to fascia and

rafters (Figure 9). Brackets and reinforcement channels are also recommended to the first rafter either side of the valley beams. Secure brackets to rafters with 12x25mm timber fixing screws through pre-drilled holes and bolt through backchannel and fascia with M10 bolts.

Note: It is the builder's responsibility to ensure the existing rafters and fascia are adequately reinforced and tied down to accommodate any additional attached structure loads.

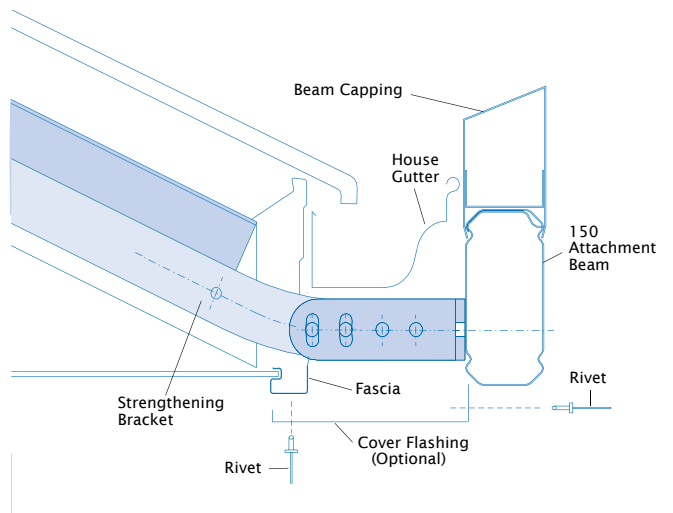

Figure 8

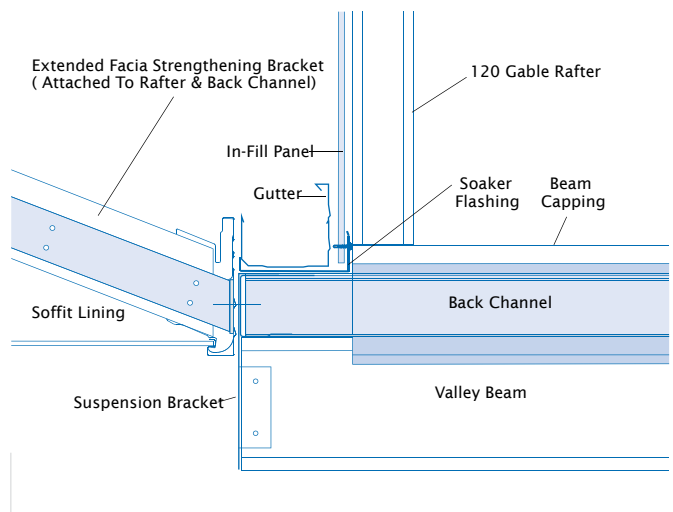

Figure 9

## 3.0 GABLE FRAME ASSEMBLY

**IMPORTANT:** Ensure that the double thickness portion is at the top when installing all beams and rafters.

Note: The rafters are supplied pre-cut and drilled at the ridge as shown in (Figure 10). Insert ridge knuckle into the pre-cut rafters and screw together using two 12x20 hex head self drilling screws through both sides of each rafter and two 12x20 hex head self drilling screws through the top (double flange side) of each rafter.

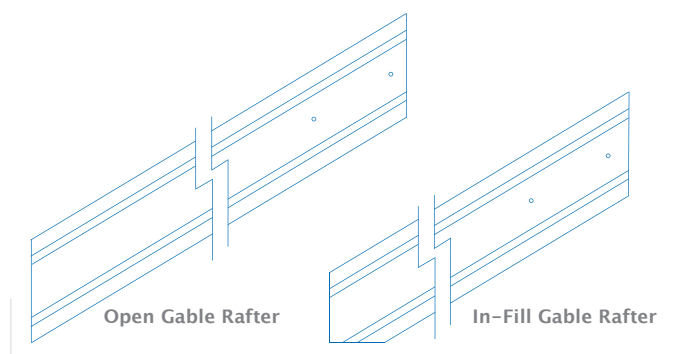

Figure 10

Pilot holes indicate screw locations as shown in (Figure 11). Make sure that the two ends are flush at the connection, leaving no gaps.

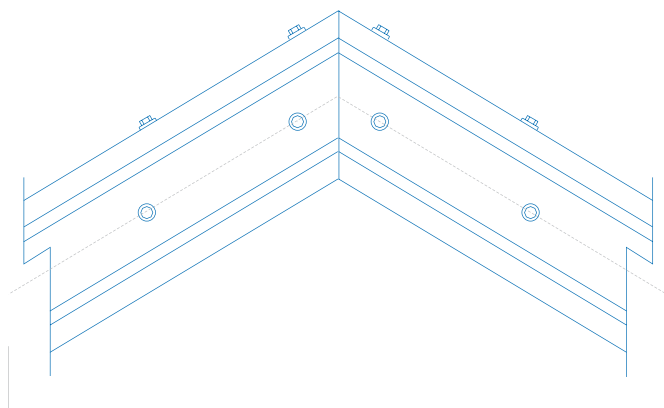

Figure 11

### 3.1 Collar Ties

If collar ties are required on intermediate frames they are to be mitred to suit the pitch of the gable rafters. For gable openings up to 6000mm collar ties are to be located mid-height of the gable frame. For gable openings greater than 6000mm collar ties are to be located at a height to give a collar tie length of 3000mm.

Collar tie brackets are to be fixed to gable rafters with four 12x20 hex head self drilling screws at the appropriate height. Collar ties are then fixed inside the brackets using two 12x20 hex head self drilling screws either side (Figure 13).

Measure the distance between rafter ends, (O), to check valley beam spacing (Figure 12).

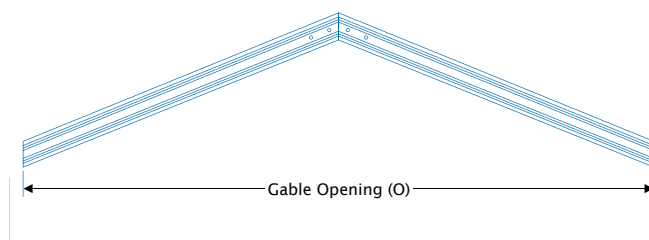

Figure 12

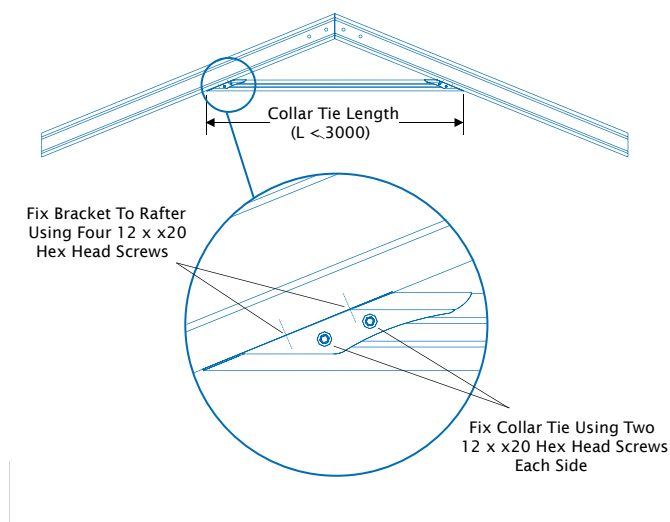

Figure 13

## 4.0 VALLEY BEAM ASSEMBLY

Before erecting the valley beams fix capping to the top of the beams. First fix beam channel to the top of the valley beam using 12x20 hex head self drilling screws at maximum 500mm centres as shown in (Figure 14). Fix the beam capping to the channel using 3mm rivets each side at maximum 500mm centres, ensuring the break is located in the top groove (Figure 14).

If attaching the valley beam to a header beam, notch the capping so that it sits on top of the beam as shown in (Figure 21).

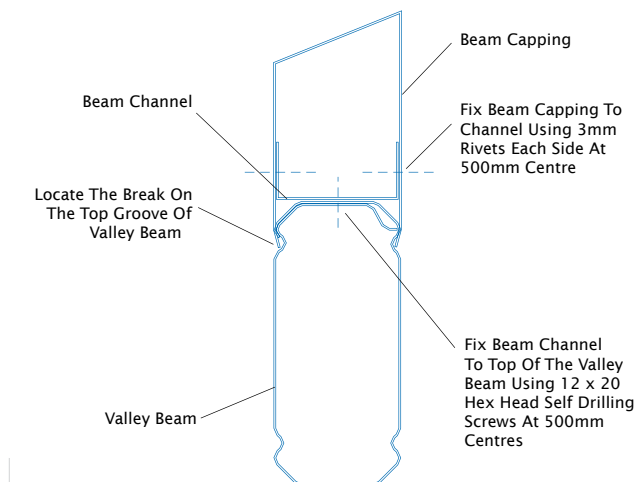

Figure 14

### 4.1 Side Attached

For side attached units fix the rafter to valley brackets to the beam capping (150 attachment beam will be considered a valley beam) at the correct rafter positions (refer Section 5) using six 12x20mm hex head screws per bracket through the pre-drilled holes (Figure 15). Please note that the bottom face of the bracket is in line with the bottom edge of the upper groove in the beam. Check positions before drilling.

If any intermediate columns are required measure the valley beam marking where they meet. Fasten post brackets as explained in 'Outback Flat Attached Verandahs, Patios & Carports' under 'Bracket and Filler Connections'. Support the second valley beam at the spacing determined in Section 3.0 on adjustable construction props.

### 4.2 End Attached

For units attached on the end to a wall, wall brackets are positioned at either side of the gable opening at the spacing determined in section 3.0. The first bracket is fastened to the wall with two M8 masonry anchors. The curved legs of the bracket are located at the top (Figure 16).

Do not anchor to mortar joints. Locate the first valley beam (beam cap on top) up into the wall bracket so the curved legs locate against the top flute of the beam.

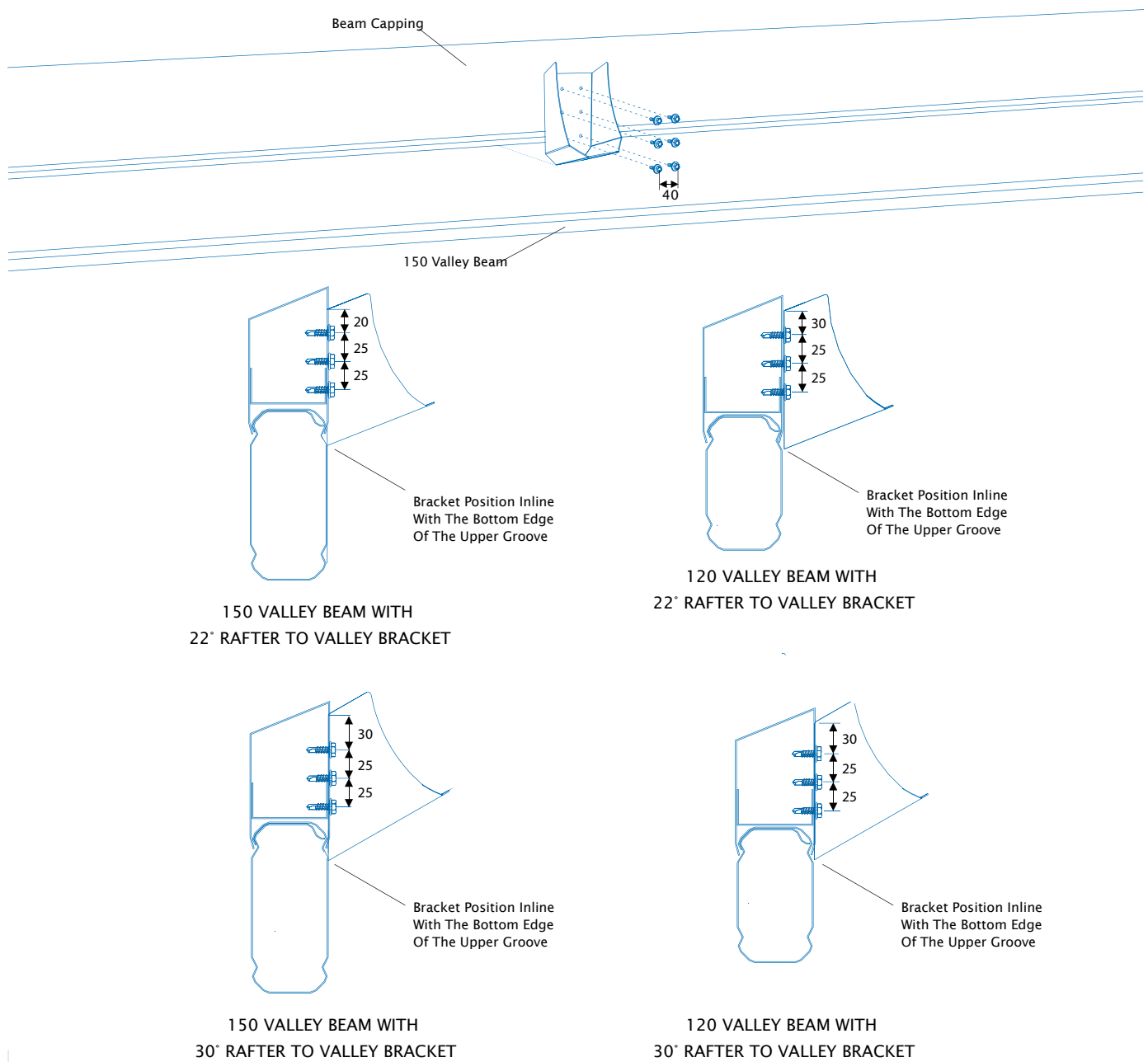

Figure 15

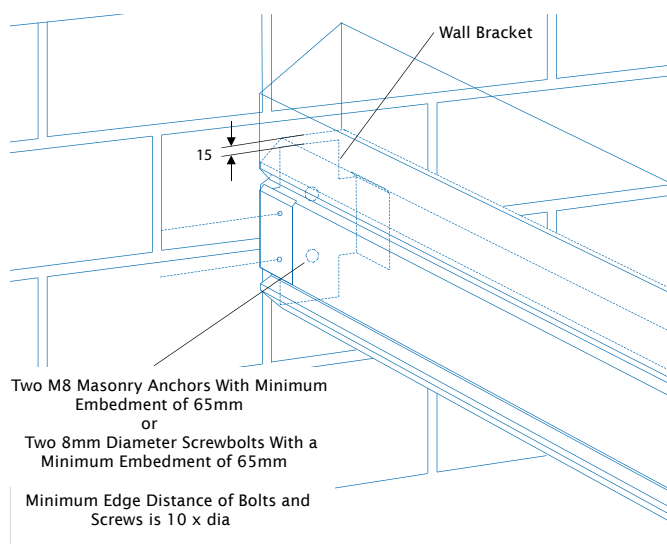

Figure 16

The valley beam is fastened to the wall bracket with 10x16 hex head screws in the pre-drilled holes while the opposite end is supported on adjustable construction props.

For units attached on the end to a fascia, suspension brackets are positioned at either side of the gable opening at the spacing determined in Section 3.0 (Figure 12). The top tab of the suspension bracket must be located between the fascia and back channel. A minimum of two M6 bolts with washers are fixed through back channel, suspension bracket and fascia (Figure 17).

If back channel is not present, (ie, no adjacent flat roof) locate a 2mm washer plate behind fascia at suspension bracket. Fix through bracket, fascia and plate.

The first valley beam is fastened into the suspension bracket with 10x16 hex head screws through the dimples while the opposite end is supported on adjustable construction props.

For units attached on the end to an attachment beam (Figure 24), beam to beam brackets are positioned at either side of the gable opening at the spacing determined in Section 3.0 (Figure 12).

Fix beam to beam brackets to the attachment beam (header beam) with two 10x16 hex head screws so they clamp the beam filler to the beam (Figure 18).

The first valley beam is fastened over the beam to beam bracket with two 10x16 hex head screws either side while the opposite end is supported on adjustable construction props.

If any intermediate columns are required measure the valley beam marking where they meet. Fasten post brackets as explained in the Stratco Installation Guide 'Outback Flat Attached Verandah, Patios & Carports' under "Bracket and Filler Connections". This can be done before valley beams are fixed in place.

Support the second valley beam on adjustable construction props but do not fix to the wall, fascia or attachment beam until the front gable frame has been attached.

Fix the rafter to valley brackets to the beam capping at the correct rafter positions (refer Section 5). Fixing details as indicated in Section 4.1.

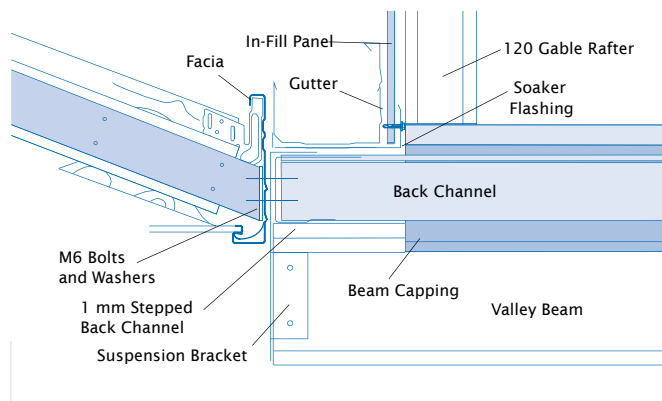

Figure 17

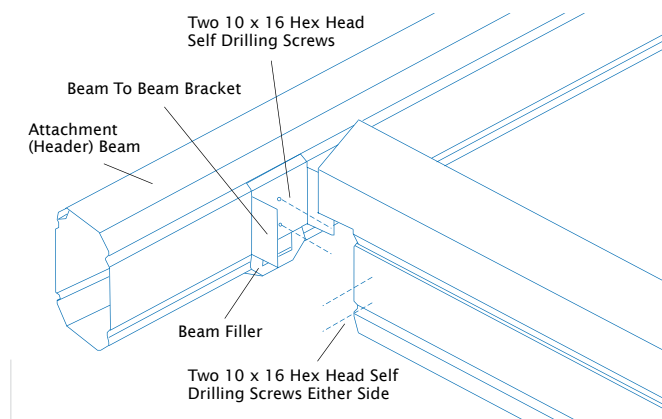

Figure 18

## 5.0 GABLE FRAME CONNECTION

### 5.1 Gable Frames

The rafter to valley brackets are attached to the beam capping using six 12x20 hex head screws (Figure 15, Section 4.1) at the appropriate locations.

Fix the gable rafters into the rafter to valley brackets with two 12x20 hex head screws either side (Figure 19).

If attached on the end, attach the second valley beam into the wall or suspension bracket.

Intermediate frames should be spaced evenly and fixed into rafter to valley brackets as previously described.

A rear gable frame without a header beam is fixed as per an intermediate frame.

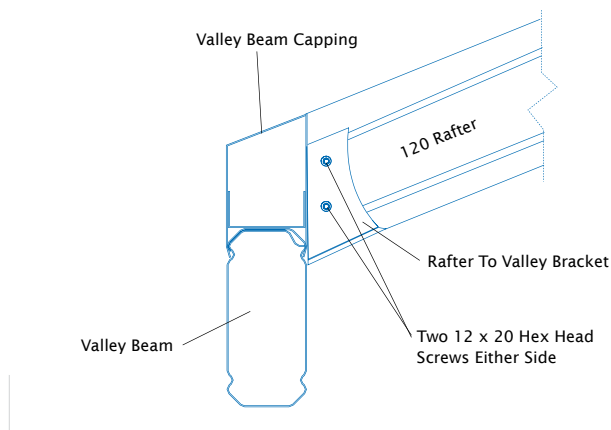

Figure 19

### 5.2 Gable Frame With Infill

#### 5.2.1 Front Infill

Where there is an infill at the front of the unit (and/or rear, in the case of side attached), run the front fascia beam of the flat roof section (if applicable) continuously across the opening to support the infill panel and form a header beam (the gutter subsequently runs full length of the header beam). Measure the end gable frame opening and attach gable beam brackets to the header beam at the appropriate spacing using a minimum of four 10x16 hex head self drilling screws.

Rafters are supplied notched at the base to fit the gable beam brackets. Rafters are fastened inside the gable beam brackets with a minimum of three 10x16 hex head self drilling screws either side as shown in (Figures 20 or 21).

#### 5.2.2 Rear Infill

A rear header beam will be required if the unit includes infill to the rear gable frame. For units attached at the rear with suspension brackets, the rear header is fixed between valley beams using beam to beam brackets. If fixed at the rear to an attachment beam (Figure 22), the attachment beam becomes the header (valley Rafters are supplied notched at the base to fit the gable beam brackets. Rafters are fastened inside the gable beam brackets with a minimum of three 10x16 hex head self drilling screws either side as shown in (Figures 20 or 21).

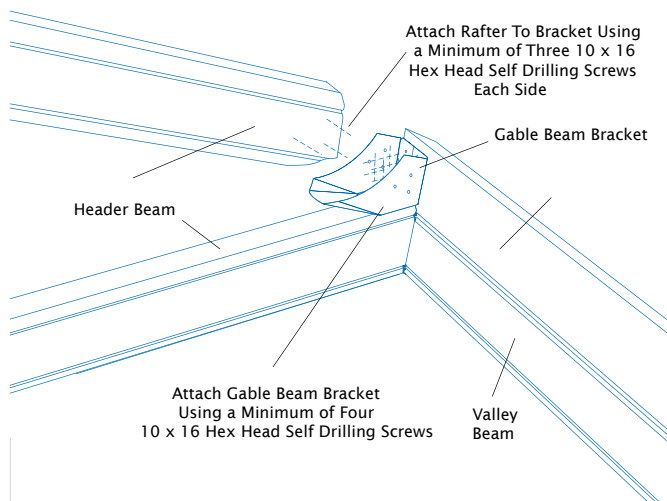

Figure 20

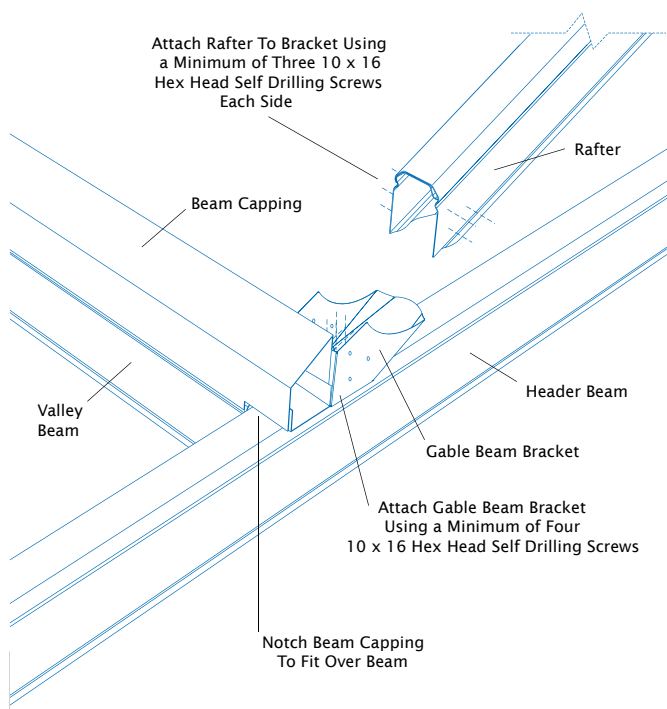

Figure 21

### 5.2.2.1 Soaker Flashing

In the case of a rear infill panel, a soaker flashing is used to conceal the existing house gutter, waterproof the rear end of the gable and neatly finish the base of the in-fill panel (Figure 22).

The rear gable frame and header beam are set back in order to accommodate the standard soaker flashing which is optional with the Outback unit (Figure 23). The frame is fixed on the rear header beam into gable beam brackets as previously detailed.

Fix the standard soaker flashing into position on top of the back channel and underneath the gutter. Infill panels must be fixed with split tail soft pull rivets at 500mm centres a minimum of 20 mm above the pan of the soaker flashing.

This will reduce the possibility of moisture being absorbed into the sheet. See Section 14 for details of fixing infill panels to gable frames.

### Note:

1. A custom made soaker flashing will need to be ordered to the required dimensions. The rafter setback will need to be adjusted to suit.
2. Do not form stop ends at either end of the soaker flashing.
3. Soaker flashing is not to come in contact with the base of the house gutter.

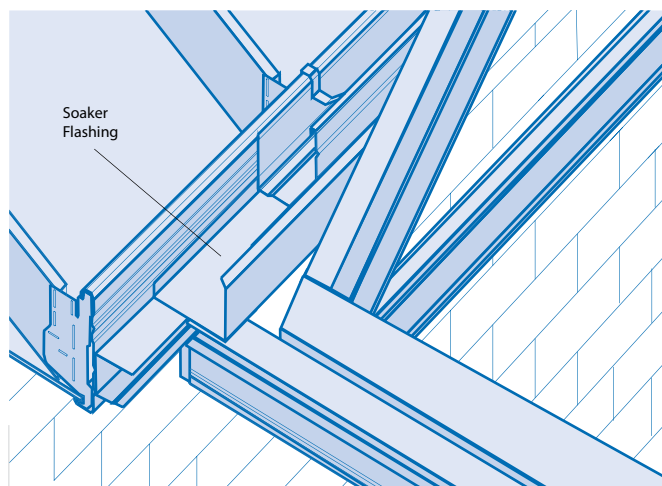

Figure 22

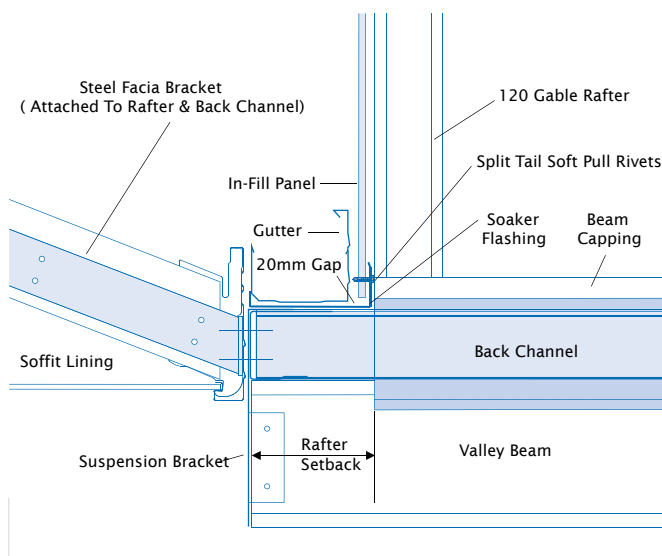

Figure 23

### 5.2.2.2 Header Flashing

When a gable is fixed at the rear to an attachment beam, elevated to the existing house gutter height, typically a header flashing is used in conjunction with the rear infill. In this case, the rear attachment beam is considered a header and along with the rear gable frame is fixed as close as possible (within 5mm) to the existing gutter in order to accommodate the header flashing. The gable frame is fixed on the rear header to gable beam brackets as previously described.

Fix the header flashing into position over the existing gutter lip with rivets. Infill panels are located behind the header flashing and fixed with split tail soft pull rivets at 500mm centres (Figure 24).

Refer Section 14 for details of fixing infill panels to gable frames.

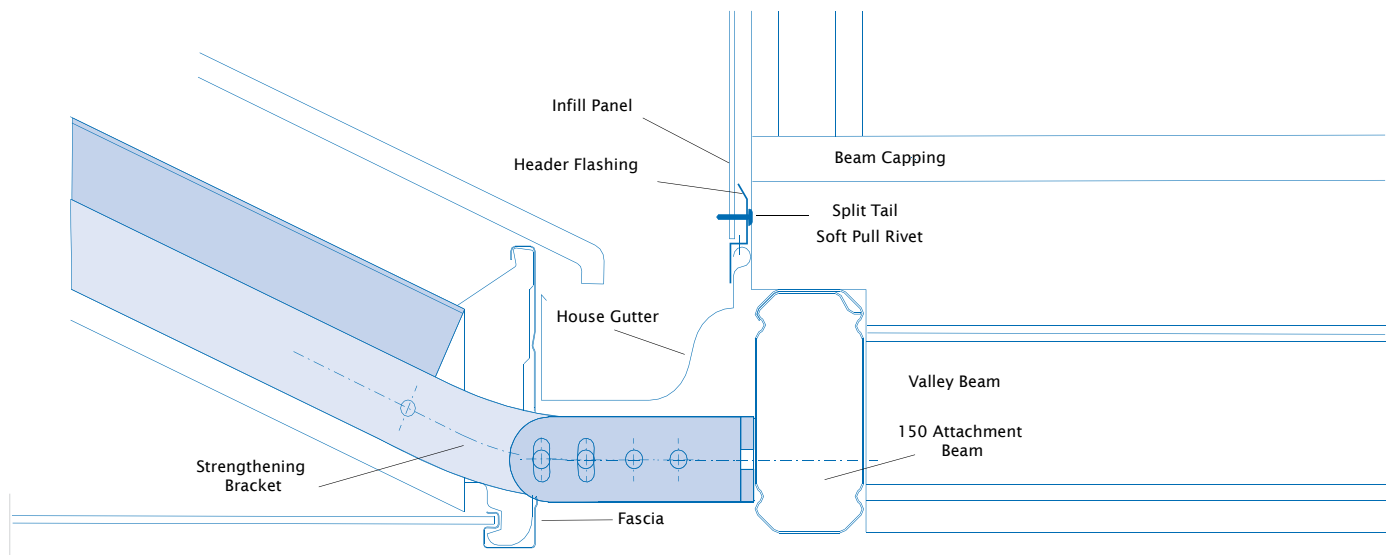

Figure 24

## 6.0 RIDGE BEAM

### 6.1 Assembling Ridge Beam

Assemble ridge beam before attaching to gable frames. Fix angled back channel to both sides of the ridge beam using 10x16 hex head self drilling screws at 500mm centres, ensuring that the top of the back channel is in line with the bottom of the beam chamfer as shown in (Figure 25). The back channel should run 34mm past the end of the beam at both ends of the ridge beam. If there is no rear portal frame, finish the back channel flush at one end.

Fasten 10x16 hex head self drilling screws at 500mm centres along the double flange of the ridge beam (Figure 25).

In the case of decking overhanging the gable frame, run the angled back channel to the end of the overhanging ridge beam as shown in (Figure 26). A ridge rafter bracket will be required on both sides of the ridge to support overhang.

### 6.1 Attaching Ridge Beam

Fix the ridge rafter bracket at the ridge with six 12x20 hex head self drilling screws through the gable frame and into the ridge knuckle.

Position the ridge beam so that the angled back channel rests on the gable frame (Figure 27). Fix the ridge rafter bracket using two 12x20 hex head self drilling screws each side (top screw may be fastened through the backchannel into the bracket & beam).

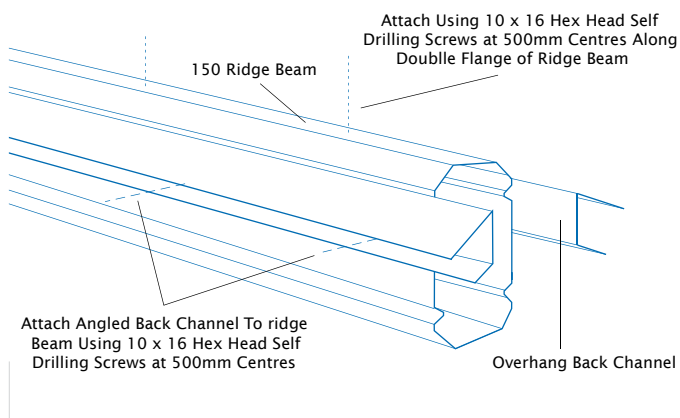

Figure 25

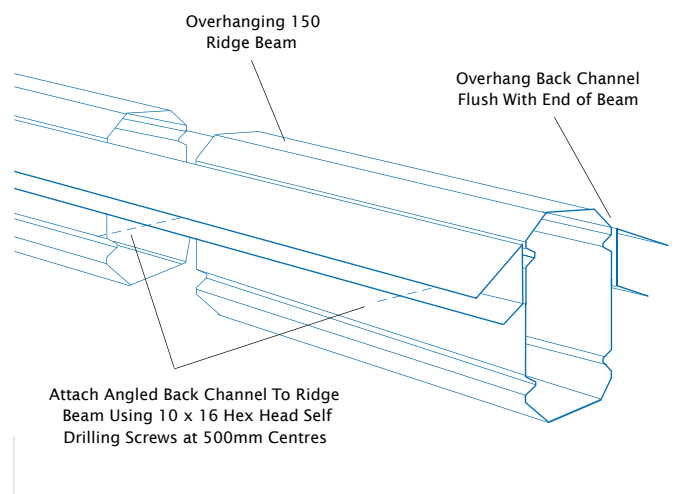

Figure 26

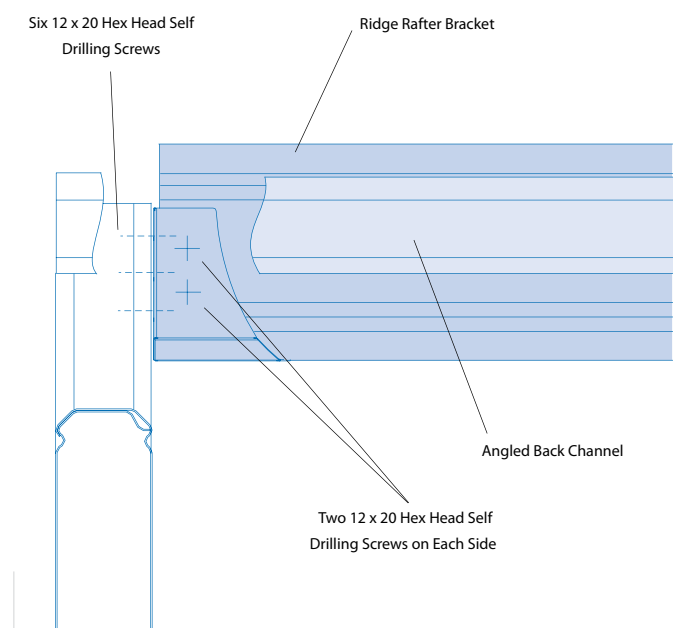

Figure 27

## 7.0 REMAINING ASSEMBLY

Assemble the remaining framework of the flat verandah (if applicable) as per the installation guide; 'Outback Flat Attached Verandah, Patios And Carports'.

## 8.0 COLUMNS AND FOOTINGS

If fixing the columns into the ground, dig the holes to the specified size. Place a full or half brick in the bottom of the hole as shown in (Figure 29).

Measure from the underside of the beam to the top of the brick and cut posts to this length at each post location.

### 8.1 68 Outback Column

If 50x50 mm square hollow sections (SHS) have been supplied, the fluted 68 Outback columns will need to be reinforced.

Cut the 50mm SHS 75mm shorter than the fluted post and slide into the column.

Ensure the square section is positioned inside the column and fix using two 12x20 hex head screws per side, at both ends, as detailed in figure 28 and 29.

Regardless of whether the column is reinforced, slide the top of the 68 Outback column over the installed post bracket until it is flush with the underside of the fascia beam.

The unfluted faces of the column should be aligned with each face of the post to beam bracket.

Fasten the 68 Outback column to the post bracket using two 12x20 hex head screws either side as shown in (Figure 29).

Use construction props or bracing to hold columns in position, but do not concrete in place at this stage.

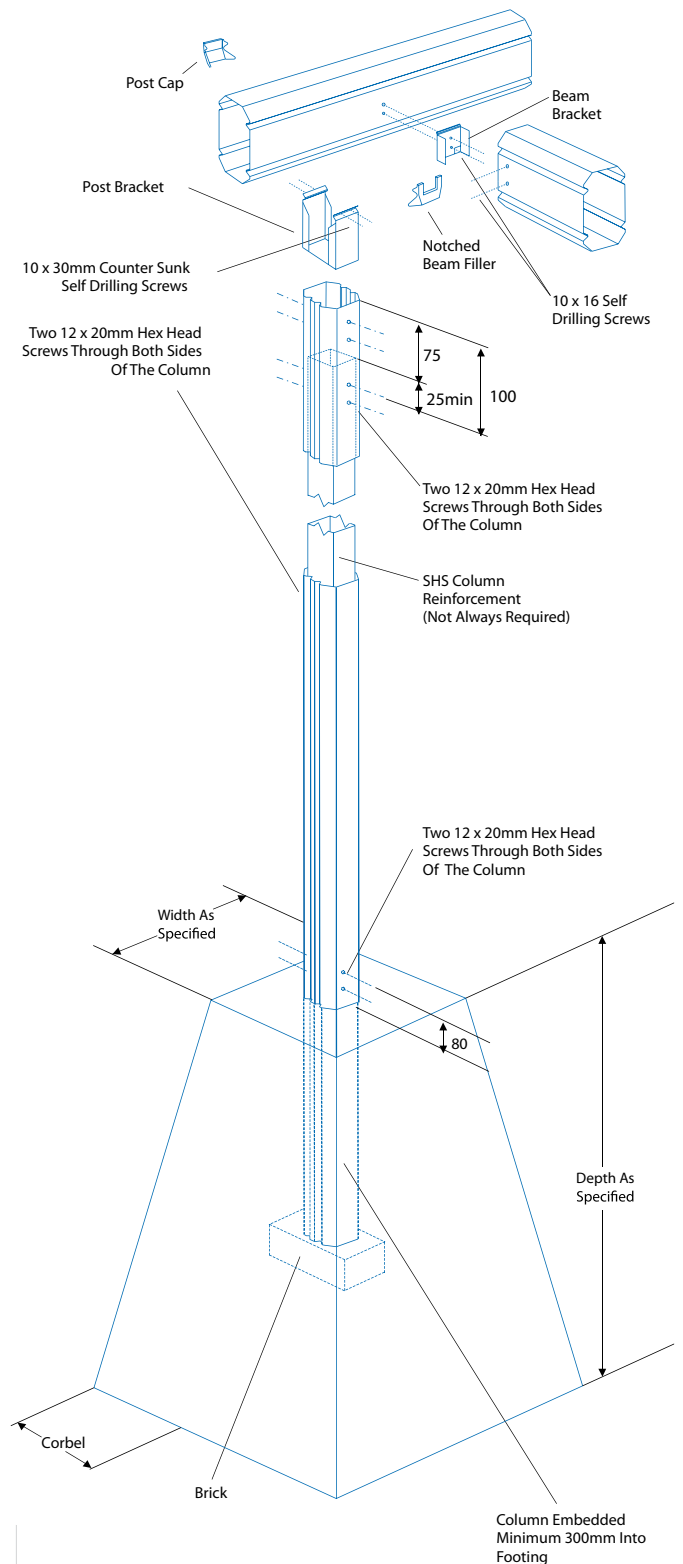

Figure 29

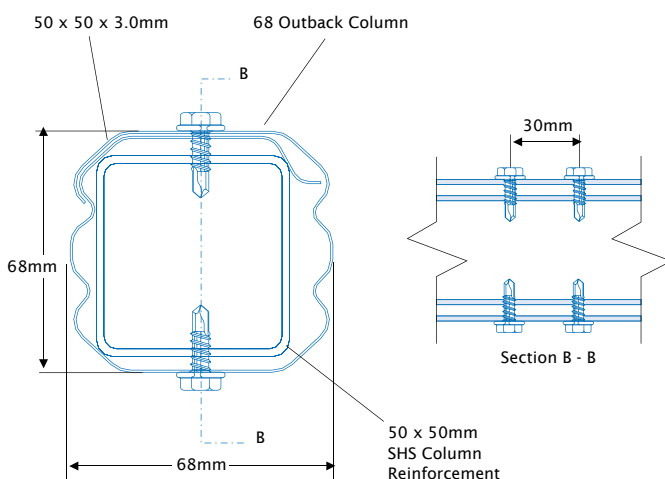

Figure 28

## 9.0 FOOTING PLATES

Footing brackets are available when fixing posts to an existing concrete slab.

Establish the column lengths by measuring the distance from the underside of the fascia beam to the concrete slab, less the thickness of the footing plate (or 20mm for Outback footing plate).

### 9.1 68 Outback Column Footing Plate

For non-reinforced 68 Outback posts, cut the columns to length, and assemble the footing bracket by sliding the legs of the footing upstand through the slots in the footing plate (Figure 30). The upstand bracing must be located between the legs of the upstand.

Slide the assembled footing bracket and bracing into the bottom of the column, and fasten with two 12x20 hex head screws either side ensuring the top screws are located at least 15mm from the top of the upstand with screws being a minimum 30mm apart. This is shown in (Figure 30).

Slide the top of the column over the post bracket and align the column and footing bracket. (it may be necessary to lift the fascia beam slightly to slide the column over the post bracket). The unfluted faces of the column should be aligned with each face of the post to beam bracket. Fasten using two 12x20 hex head screws either side as shown in (Figure 29).

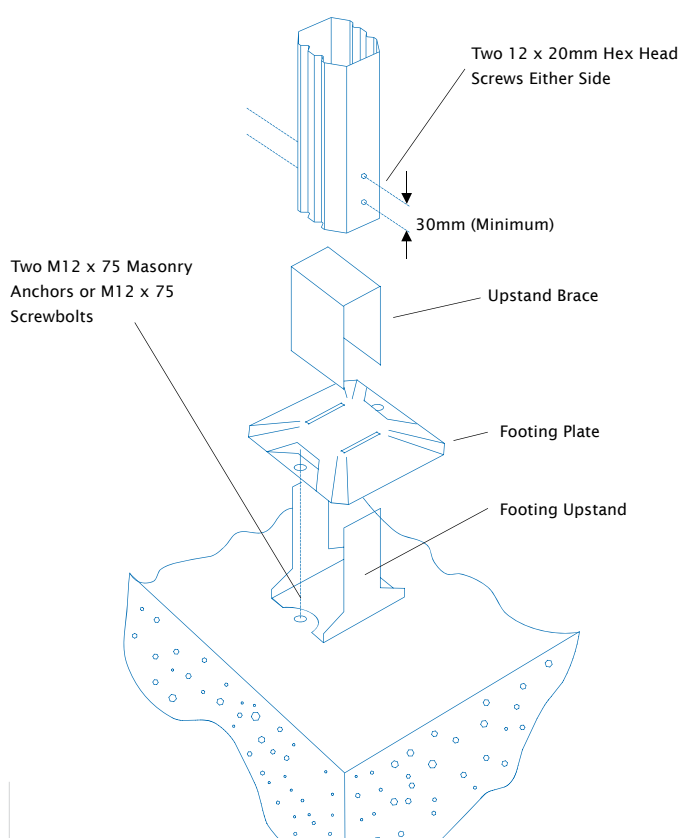

Figure 30

the post to beam bracket. Fasten using two 12x20 hex head screws either side as shown in (Figure 29).

Use construction props or bracing to hold columns in position but do not bolt to the concrete slab at this stage.

### 9.2 SHS Reinforced Column Footing Plate

Slide the SHS reinforced footing bracket into the bottom of the column, pre-drill and fasten with two 12x20 hex head screws on either side of the post. Locate the top screws approximately 100mm from the base of the footing plate, and the bottom screws 50mm from the base. This is shown in (Figure 31).

Slide the top of the column over the post bracket and align the column and footing bracket. (it may be necessary to lift the fascia beam slightly to slide the column over the post bracket). The unfluted faces of the column should be aligned with each face of the post to beam bracket. Fasten using two 12x20 hex head screws either side as shown in (Figure 29).

Use construction props or bracing to hold columns in position but do not bolt to the concrete slab at this stage.

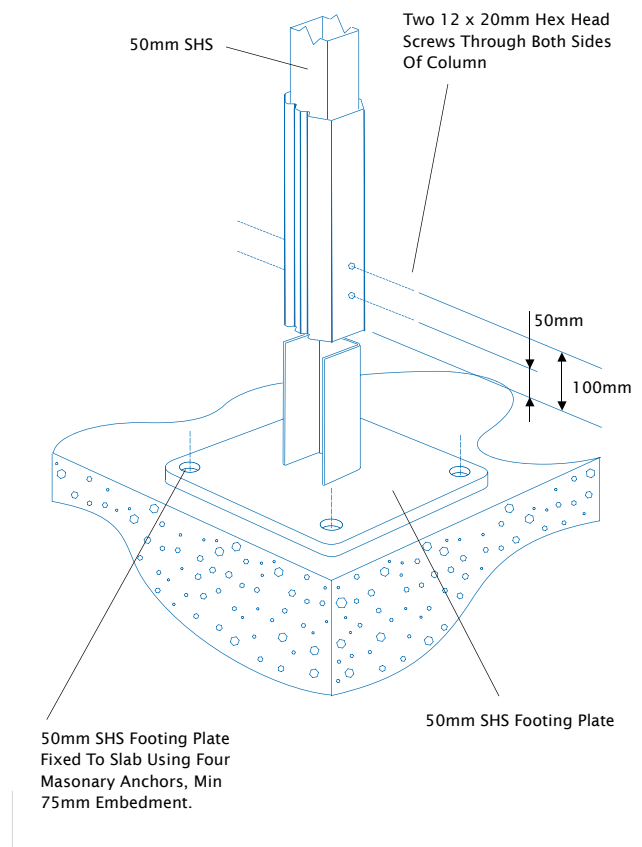

Figure 31

## 10.0 CAPPING

To prevent moisture from entering the beams and for aesthetics, any beams with exposed ends require endcaps be fitted. Align the endcap and push into the exposed beam end. The postcaps can be fitted over the post-beam connection. Align the two lugs with the two exposed holes of the post bracket and push firmly.

## 11.0 GUTTERING

If a flat verandah is included connect the gutter to the flat roof Outback as described in 'Outback Flat Attached Verandah, Patios & Carports'.

Where there is no flat roof adjacent the gable, the gutter is attached to the top of the beam capping. Cut 30mm tabs in the gutter back lip at 1000mm intervals and fold back. Fix the gutter to the beam capping, through the tabs with rivets as shown in (Figure 32). Once decking is attached (Section 12.0) fit gutter straps at maximum 1000mm intervals, attaching to the top of the decking with rivets. Waterproof rivets with silicone.

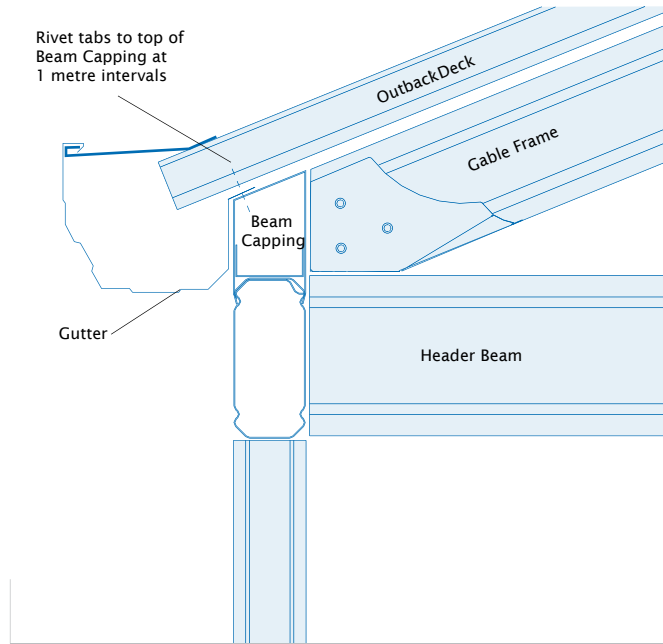

Figure 32

### 11.1 Gutter Outlet Assembly

Position the downpipes in line with columns then cut a hole in the base of the gutter near the back chamfer. Insert the downpipe outlet from the inside of the gutter and rivet in place using 3mm rivets (Figure 33). Remove any swarf and waterproof with silicone.

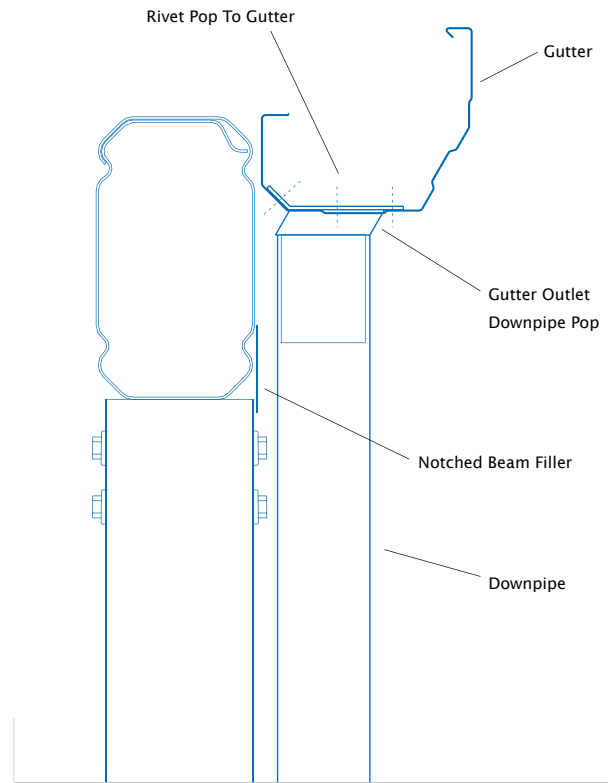

Figure 33

## 12.0 ATTACH DECKING

### 12.1 Flat Roof (If Applicable)

Attach the decking to the flat roof verandah first as laid out under "DECKING" ("Outback Flat Attached Verandah, Patios & Carports"), starting from the valley beam and working away, on both sides.

The back channel is attached upside down (the shorter leg on top) along beam capping to assist the fixing of decking. (Figure 34).

### 12.2 Clearspan Gable

When attaching the decking to the gable, start from the rear on one side of the gable. Fix the deck to the angled back channel at the ridge, and to the capping at the valley beam. If the deck of the flat roof section runs perpendicular to the valley beams, align the ribs of the gable decking up with the flat roof section. The Outback decking will need to overhang the beam capping allowing water to flow directly into the gutter (Figure 32).

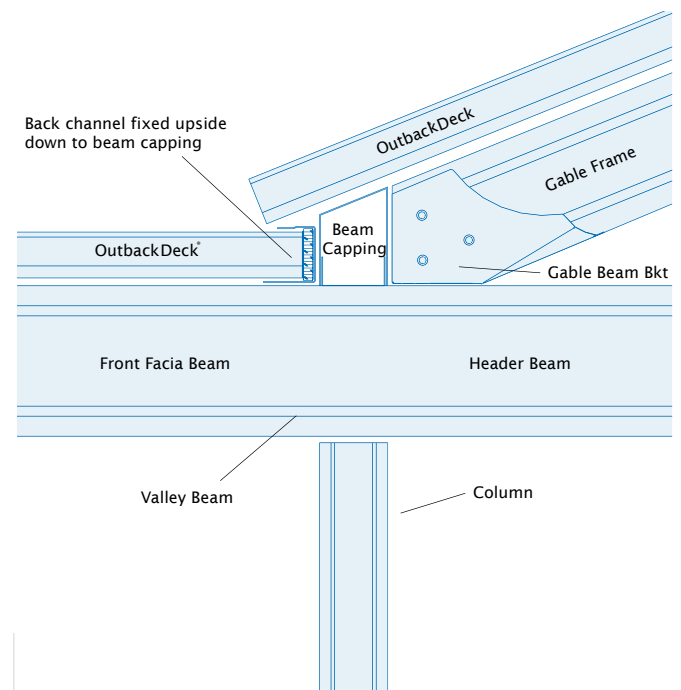

Figure 34

## 13.0 RIDGE CAPPING

### 12.2 Clearspan Gable

When attaching the decking to the gable, start from the rear on one side of the gable. Fix the deck to the angled back channel at the ridge, and to the capping at the valley beam. If the deck of the flat roof section runs perpendicular to the valley beams, align the

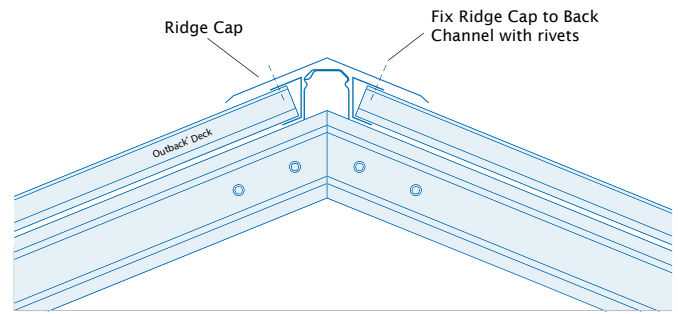

Figure 35

## 14.0 INFILL PANELS

ribs of the gable decking up with the flat roof section. The Outback decking will need to overhang the beam capping allowing water to flow directly into the gutter (Figure 32).

Position the ridge cap over the ridge beam and two angled back channels and rivet into the channel (Figure 35). Position the ridge cap over the ridge beam and two angled back channels and rivet into the channel (Figure 35).

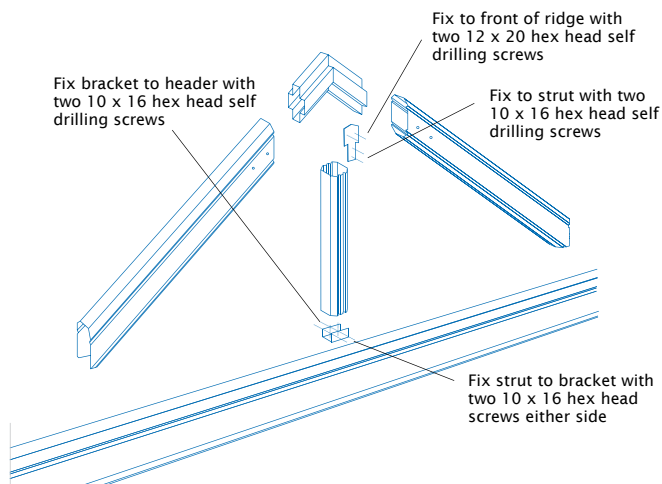

Figure 36

Two styles of header flashings are available to neatly finish the base of infill panels, one is used on header beams with gutter and the other for headers without gutter. Gable infill panels are to be cut in triangular shapes to fit the end frame. Panels can be painted to the desired colour before installing.

End struts are fixed mid-span of the header to a header beam bracket at the base and an end strut plate at the ridge (Figure 36).

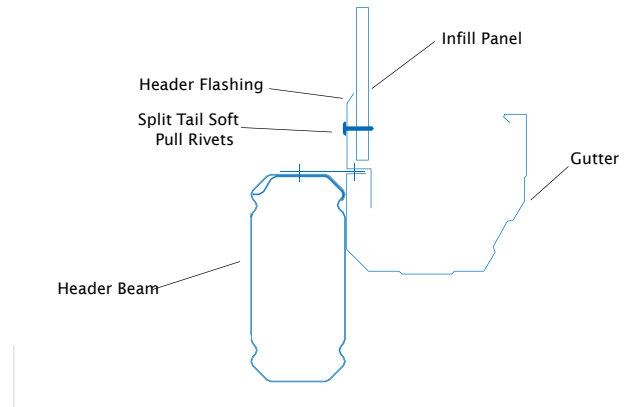

Figure 37

### 14.1 Header Beam With Gutter

Attach the header flashing to the rear gutter lip with rivets. Infill panels are fixed through the top groove of rafters and the end strut with 8x35mm self embedding self drilling screws at maximum 500mm centres in non-cyclonic areas and 250mm centres in cyclonic areas. Panels are fixed at the base through the header flashing with split tail soft pull rivets at maximum 500mm centres (Figure 37).

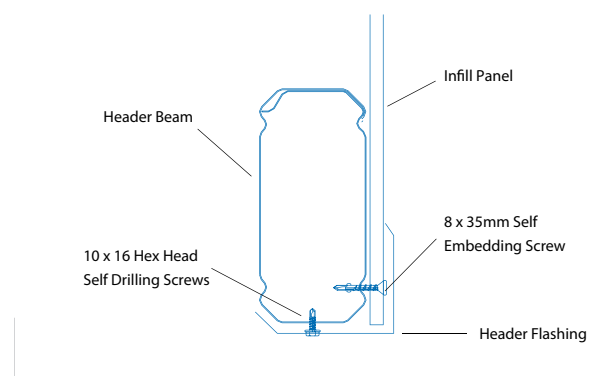

Figure 38

## 15.0 ATTACHING BARGE CAP

### 14.2 Header Beam Without Gutter

Infill panels are fixed through the top groove of rafters and the lower groove of the header beam with 8x35mm self embedding self drilling screws. Fix at maximum 500mm centres in non-cyclonic areas and 250mm centres in cyclonic areas. Panels are fixed to the end strut at the same spacings. Attach the header flashing to the underside of the header beam with 10x16 hex head screws to neatly finish the base of the infill panels (Figure 38).

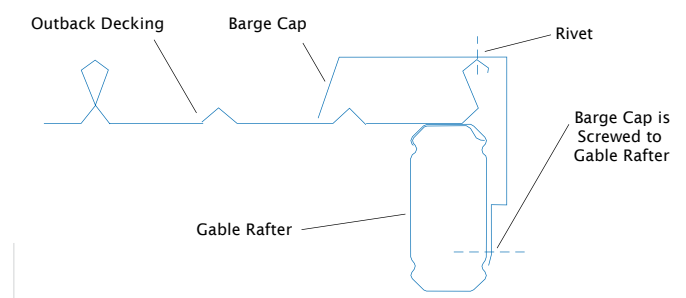

Figure 39

CONTACT

1300 165 165

## 16.0 FINAL FIXING

If barge capping is required at the ends of the unit, attach the barge cap by screwing the lower lip to the rafter and rivet the top section to the deck, as shown in (Figure 39). Mitre the barge at the apex of the gable for a neat finish. Run the barge cap along the gable section to where it meets the flat verandah deck and finish neatly.

Before securing columns in position ensure a minimum fall of 1 in 500 (12mm for every 6m) towards downpipe/s.

### 16.1 Final Fixing Into Concrete

Thoroughly check posts with a spirit level. When plumb, fill the post hole with approximately 150mm of concrete and use a shovel or pole to agitate the concrete to remove and air pockets. Repeat this process until the hole is full, continually checking the posts. Once the concrete is set remove any temporary bracing or props. The concrete must be finished slightly raised towards the column to ensure water runs away from the column.

### 16.2 Final Fixing Onto Existing Concrete

If fixing the columns to an existing concrete slab with a footing plate, each plate must be fixed to the concrete as specified in (Figures 30 or 31) as appropriate. The minimum distances from an anchor hole to the concrete edge is 75mm.

### 16.3 Downpipes

Before attaching the downpipes, rivet the downpipe bracket to the column and bend the flanges along the 'break-line' to accept the downpipe. Slide the downpipe over the downpipe outlet and rivet into position. Rivet the downpipe to the brackets. Weatherproof all fasteners with silicone.

## 17.0 HELPFUL TIPS

Leave plastic coating on members until they are about to be fastened to the structure. This will help prevent scratching of the colorbond® finish.

Sweep the roof and clean gutters after the completion of work. Ensure any swarf and rivet stubs are removed as they can cause unsightly rust stains.

Double check all measurements and drilling locations before proceeding.

Regularly check framework for squareness and vertical alignment to make sure it hasn't moved during construction.

Leave all construction props and/or bracing in place until concrete is set or columns are bolted to the slab.

## 18.0 MAINTENANCE

You have now completed your new Stratco Outback. Your Stratco Outback will give you many years of service by simply following the important recommendations set out in the Stratco 'Selection, Use and Maintenance' brochure.

We recommend you wash and wipe down your Stratco Outback unit with a soft broom, mop or sponge as frequently as you would wash your car to maintain its duco. More frequent cleaning and rinsing will be required in severe environments.